

Northeast Community College
Diversified Manufacturing Technology

Series Circuits

PURPOSE:

The following experiment is designed to illustrate the major characteristics of a series circuit. It will provide experience in measuring and calculating electrical quantities in series circuits.

DISCUSSION:

Circuits consisting of just one battery and one load resistance are very simple to analyze, but they are not often found in practical applications. Usually, we find circuits where more than two components are connected together.

There are two basic ways in which to connect more than two circuit components: *series* and *parallel*. Every circuit combination, regardless of its complexity, has resistance. Because most circuits are complex it is not practical to measure each component. Therefore, knowing a few simple rules can help you to better understand the type of circuit in which you are dealing.

The rule for series-connected resistors is as follows:

The total resistance between two terminals of a series-connected circuit is the sum of the individual resistances.

$$\text{Total Resistance} = \text{Resistor 1} + \text{Resistor 2} + \text{Resistor 3} \dots$$

PROCEDURE:

1. Using the PHET Circuit Construction Kit, build the circuit identified as Figure 6-1.

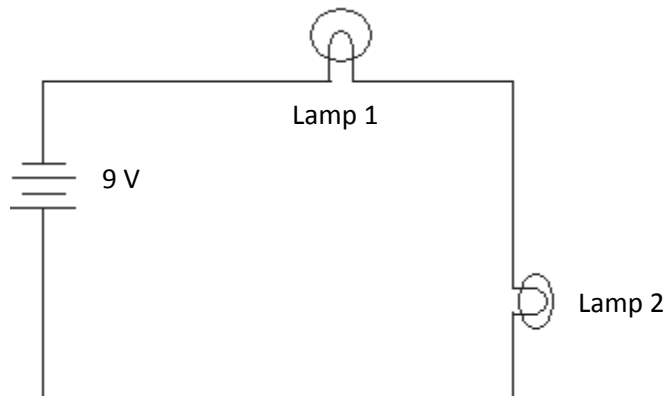

Figure 6-1

- a. Do the lamps glow with equal brilliancy? _____

b. Why? _____

c. Measure and record the voltage across each lamp and across the battery.

Battery _____ V Lamp 1 _____ V Lamp 2 _____ V

d. Does the sum of the voltages across Lamp 1 and Lamp 2 equal the voltage of the battery?

e. Interrupt the circuit between the positive terminal of the battery and lamp 2. Insert the ammeter. Measure and record the current?

Current _____ A

f. Remove the ammeter from the circuit and reinstall the ammeter between lamps 1 and 2. Measure and record the current?

Current _____ A

g. Remove the ammeter from the circuit and reinstall the ammeter between lamp 1 and the negative terminal of the battery. Measure and record the current?

Current _____ A

h. Is the current the same throughout the circuit? _____ Why? _____

2. Disconnect the ammeter from the circuit. Using the PHET Circuit Construction Kit make a short between lamp 1 and lamp 2 as shown in Figure 6-2.

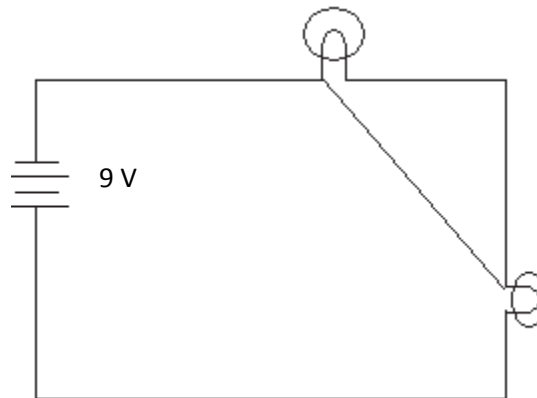

Figure 6-2

a. Describe what happens to lamp 1 and lamp 2 in terms of brightness.

Lamp 1 _____

Lamp 2 _____

- b. Although still connected, why doesn't lamp 1 illuminate?
- c. Using the non-contact ammeter measure the current between lamp 1 and lamp 2. Why is there no current between lamp 1 and lamp 2?
- d. How and why did the current between Figures 6-1 and 6-2 change.
3. Using the PHET Circuit Construction Kit, construct the circuit as shown in Figure 6-3. This would be the same effect as lamp 1 burning out or removed.

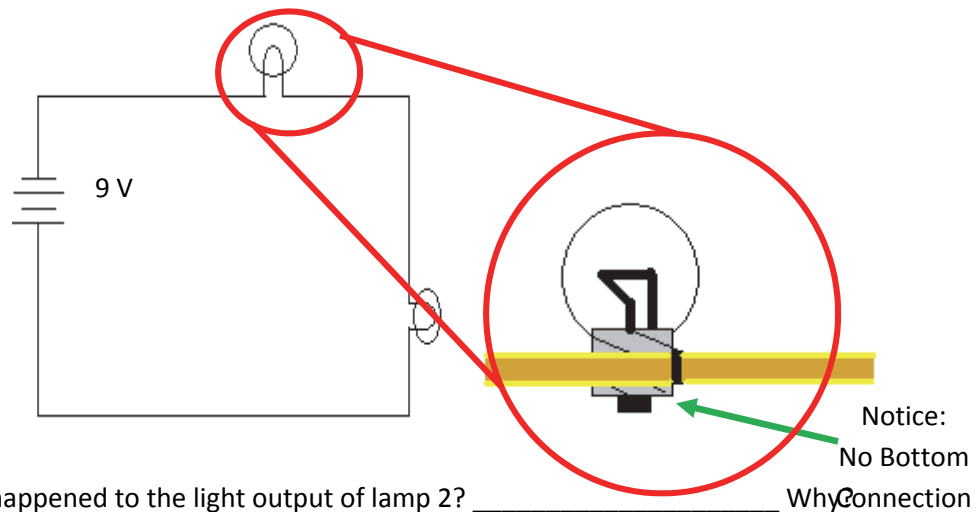

- a. What happened to the light output of lamp 2? _____ Why? _____
- b. How much voltage would you expect across lamp 2 when lamp 1 is removed? _____ V Why? _____
- c. Verify your answer by measuring and recording the voltage across lamp 2.
- Lamp 2 Voltage _____ V
- d. How much voltage would you expect across the terminals of the socket from which lamp 1 was removed? Why?

- e. Do your results support the statement that “the voltage across an open load equals the source voltage in a series circuit?”

4. Construct the circuit shown in Figure 6-4 using the PHET Circuit Construction Kit.

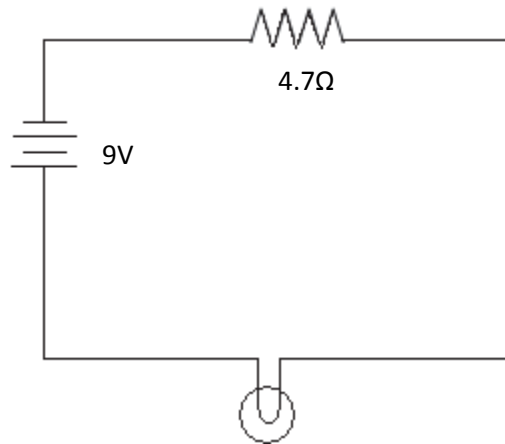

FIGURE 6-4

- a. How does the brilliancy of the lamp compare with the brilliancy of the lamp when used in Figure 6-1?
- b. Which device, the resistor or the lamp, do you think is dropping more voltage? Why? (By dropping more voltage means, has less voltage passing through the device).
- b. To test your conclusions to question 4(b), measure the voltages across the resistor and the lamp. Which has more resistance?
- c. If the $4.7\ \Omega$ resistor is replaced with a $33\ \Omega$ resistor, will the lamp get brighter or dimmer?
- d. Test your answer by changing the resistance on the resistor to $33\ \Omega$ and measure the voltage.

5. Using the PHET Circuit Construction Kit, design the circuit shown in Figure 6-5.

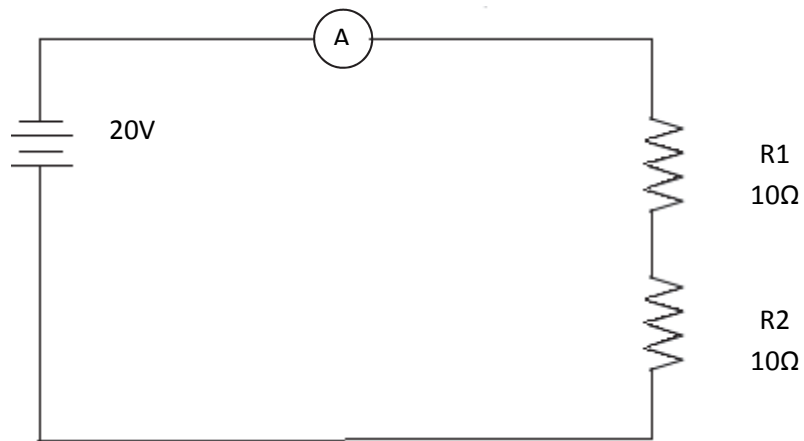

Figure 6-5

- a. Calculate and record the total resistance of the circuit in Figure 6-5.

- b. Calculate and record the total current of the circuit in Figure 6-5.

_____ A

- c. Measure and record the total current of the circuit in Figure 6-5.

- d. Measure the voltage across each of the resistors.

Resistor 1 (R1) _____ V Resistor 2 (R2) _____ V

- e. In a series circuit, do equal resistors drop the same amount of voltage? Why or why not?

- f. What can you conclude about the sum of the voltage drops across each resistor and the total source voltage?

g. Power = Voltage \times Current. Calculate how much power is dissipated across each resistor.

h. If two resistors in a series circuit are equal, was the power dissipated across each resistor equal? If no, why not?

6. Increase resistor 2 to 20 Ω .

a. By doubling the resistance of resistor 2, is the voltage of resistor 2 twice as large as the voltage of resistor 1? _____

b. Would the voltage across a 30 Ω resistor be three times as large as the voltage across the 10 Ω resistor? _____

c. If a 5 Ω resistor drops 10V, how much voltage will be dropped across a 20 Ω resistor? Notice that the voltage drops in a series circuit are in direction proportion to the individual resistances. Mathematically, this can be written:

$$\frac{R1}{R2} = \frac{V1}{V2}$$

(Resistance 1 divided by Resistance 2 equals the voltage of resistor 1 divided by the voltage of resistor 2.)

Voltage 2 _____ V

7. Construct Figure 6-6 using the PHET Circuit Construction Kit.

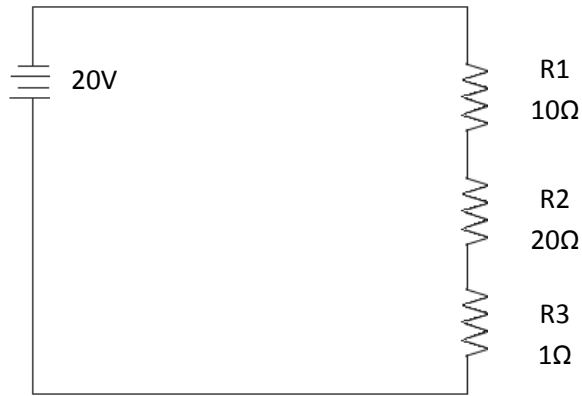

Figure 6-6

a. Would you expect the total current in Figure 6-6 to be about the same as the circuit you constructed in step 6? _____ Why or Why Not? _____

b. Predict how the voltage across resistor 2 will react. (Increase, decrease, stay the same).

c. Measure and record the voltage drop across each resistor.

R1 _____ V R2 _____ V R3 _____ V

d. How does adding the third resistor affect the power of the entire circuit?

8. You are given a circuit with three resistors have the following voltage drops; 4.2V, 10.5V, and 5.3V respectively. What is the voltage of the power supply for this specific circuit?

9. You are given a circuit with three resistors measuring as follows:

Resistor 1: 10Ω
5.56 V

Resistor 2: ??
11.11V

Resistor 3: ??
3.33V

a. Determine the resistance of resistor 2.

b. Determine the resistance of resistor 3.

10. You've looked at various components connected in series, but what about connecting a power supply in series. Construct Figure 6-7 using the PHET Circuit Construction Kit.

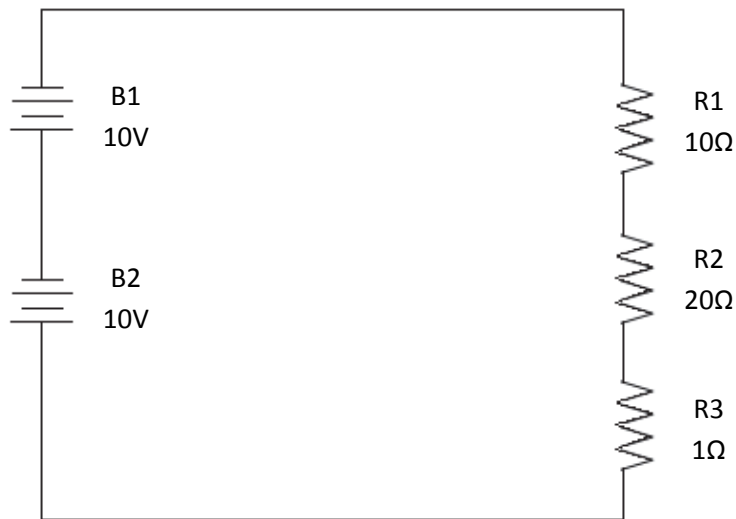

Figure 6-7

a. Measure the voltage across all three resistors and across the circuit. Record your values.

Resistor 1 _____ V Resistor 2 _____ V Resistor 3 _____ V

Total Circuit _____ V

b. Compare the voltage drops to those obtained in 7(a) and 7(c). Based upon that comparison, what relationship can you draw regarding power supplies in series?

- c. Increase battery 1 (B1) to 30 volts. Again measure and record the voltage across all three resistors.

Resistor 1 _____V Resistor 2 _____V Resistor 3 _____V

- d. By increasing the total circuit source voltage, how did the voltage across the resistors change.

- e. A team member asks for your assistance in trouble shooting the circuit shown in Figure 6-8. The problem is reported to be that the lamp will not light. The team member did replace the lamp with a brand new lamp that was verified to work properly in another system. Discuss how you might go about troubleshooting this circuit and what the source of the problem is? (You may discuss the problem and possible solutions with your classmates)

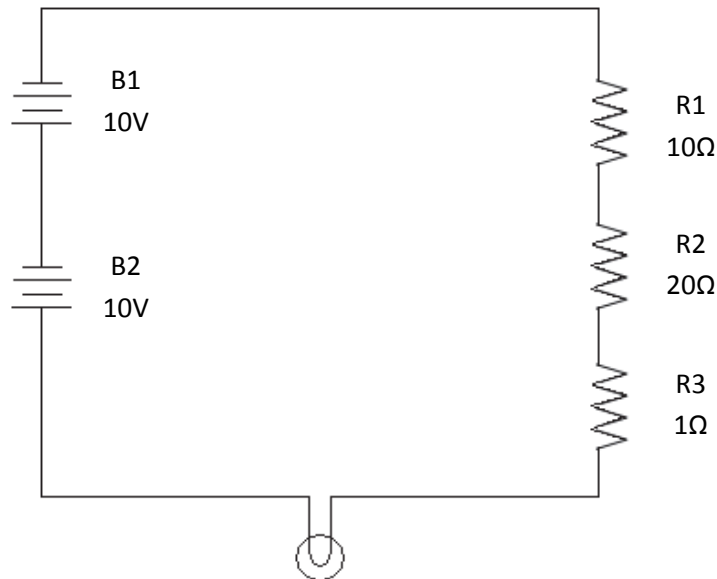

Figure 6-8

Resources:

1. University of Colorado Boulder (n.d.). [PhET - Circuit Construction Kit](#).

Founded in 2002 by Nobel Laureate Carl Wieman, the PhET Interactive Simulations project at the University of Colorado Boulder creates free interactive math and science simulations. PhET sims are based on extensive education research and engage students through an intuitive, game-like environment where students learn through exploration and discovery.

2. Grant Statement

This document was developed as part of Trade Adjustment Assistance Community College and Career Training (TAACCCT) Grant Program Round 2 Grant, Innovations Moving People to Achieve Certified Training (IMPACT): TC-23752-12-60-A-31.



Unless otherwise noted, this work by the Project IMPACT Nebraska Community College Consortium is licensed under the Creative Commons Attribution 4.0 International License. To view a copy of this license, visit [CreativeCommons.org](http://creativecommons.org/licenses/by/4.0/) or <http://creativecommons.org/licenses/by/4.0/>.

This product was funded partial or in full by a grant awarded by the U.S. Department of Labor's Employment and Training Administration. The product was created by the grantee and does not necessarily reflect the official position of the U.S. Department of Labor. The Department of Labor makes no guarantees, warranties, or assurances of any kind, express or implied, with respect to such information, including any information on linked sites and including, but not limited to, accuracy of the information or its completeness, timeliness, usefulness, adequacy, continued availability, or ownership.