

# SLC-500 Hardware Basics

Created by Tom Wylie, 5/22/17

# SLC-500 Hardware Basics

After viewing this document, the student should be able to:

1. Identify what PLC training units will be used in this course
2. Identify the basic sections of a programmable logic controller
3. Explain how signals flow from discrete input devices to the PLC data file memory
4. Explain how signals flow from the output image table to the discrete output module and devices
5. Determine what software and hardware are required to build a programming panel for an AB PLC
6. Interpret PLC input and output modules on an electrical print
7. Determine what turns on the status lights on PLC discrete input and output modules
8. Explain the scan sequence of the SLC-500 processor
9. Explain the Run and Program modes of the processor
10. Determine what instructions should be highlighted in a PLC program

# Please Read This

This document is to overview the operation of a PLC system, based on the hardware the student will use in the PLC lab.

The intent of the document is the student to get a good understanding of the hardware used in the course, as well as the software that will be required to program and troubleshoot the PLC. This will be an overview of the PLC processor, basics on discrete I/O modules, and the PLC power supply.

# The SLC-500 Training Unit:

The student should understand what all the components on the training unit are, and their purpose. PLC200 will be on just discrete I/O. Analog I/O is discussed in the Instrumentation course, and in the Programmable Controller II courses.

Allen Bradley SLC-500 Training Unit

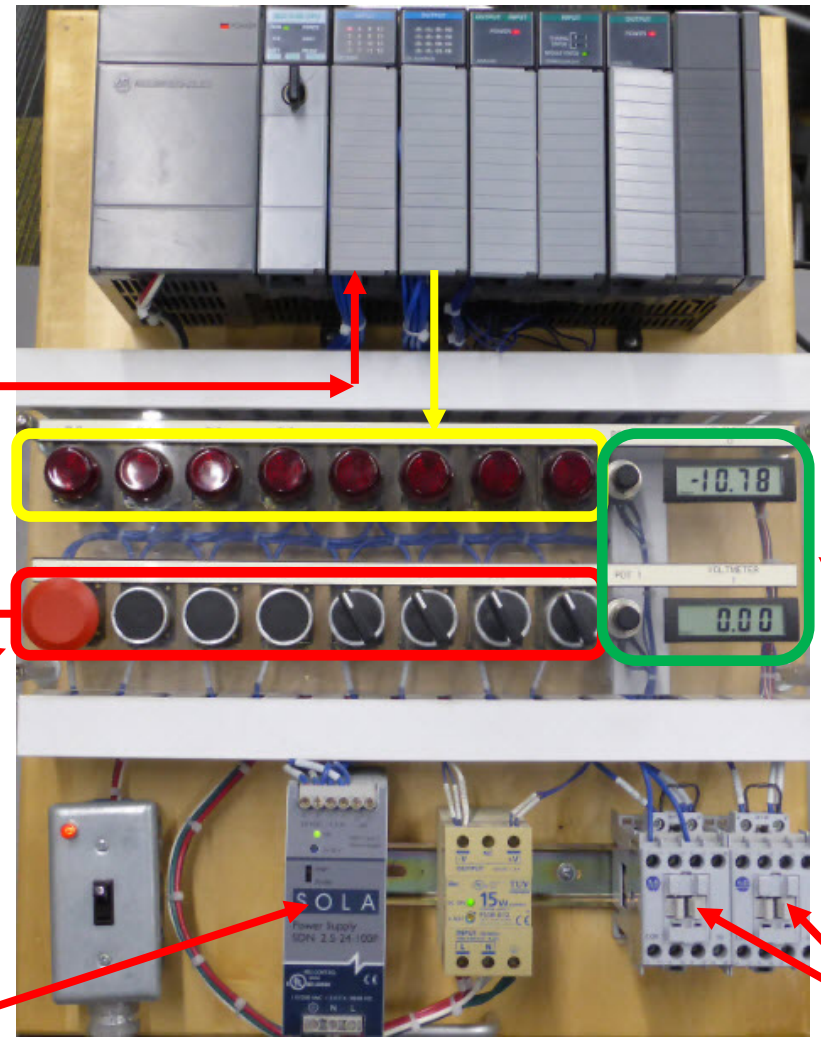

8 discrete input switches wired to the DC input module

24Vdc system power supply

Two potentiometers, and two numeric displays, wired to the analog I/O module in module slot 3

Two 24Vdc Contactors wired to output terminals 8 & 9 of the DC output module

# SLC-500 Processor Basics:

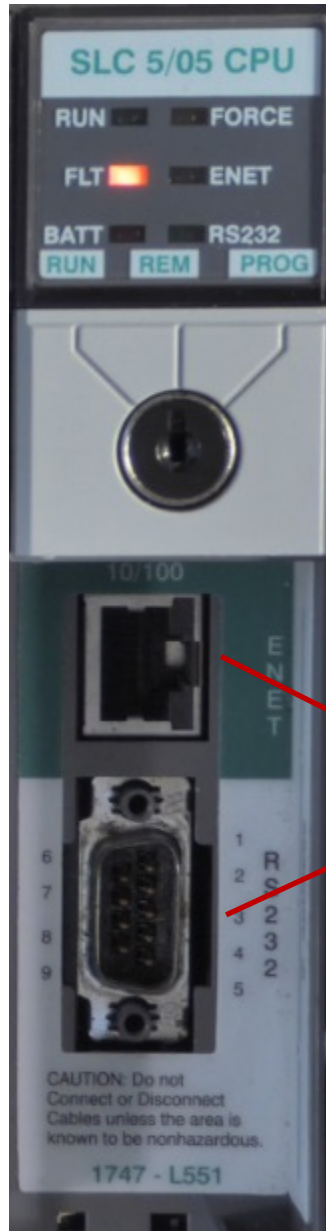

The Processor  
Diagnostic Indicators

The Processor  
Key Switch

Processor  
Communication Ports

The PLC processor is the brains of the PLC system. The processor holds the PLC program, the software that actually runs the machine. This program is typically designed by a Controls Engineer.

Diagnostic indicators on the front of the processor will show the status of the unit. When the processor is put into the **Run Mode**, the scan starts and the outputs are enabled. When the processor is put into the **Program Mode**, the scan stops and the outputs are disabled.

3 basic parameters that determine which processor is chosen for an application are:

- \*The number of I/O it can control

- \*Amount of RAM memory. This parameter will determine the size of the program that the unit will be able to handle. SLC-500 units are 16K or 32K (1K = 1,024 words).

- \*Scan Time. Traditional PLC units have a scan time. This is the amount of time it takes to scan the program and update the I/O. On an SLC-500 unit this is .5 msec.

# Communication Ports on the Processor:

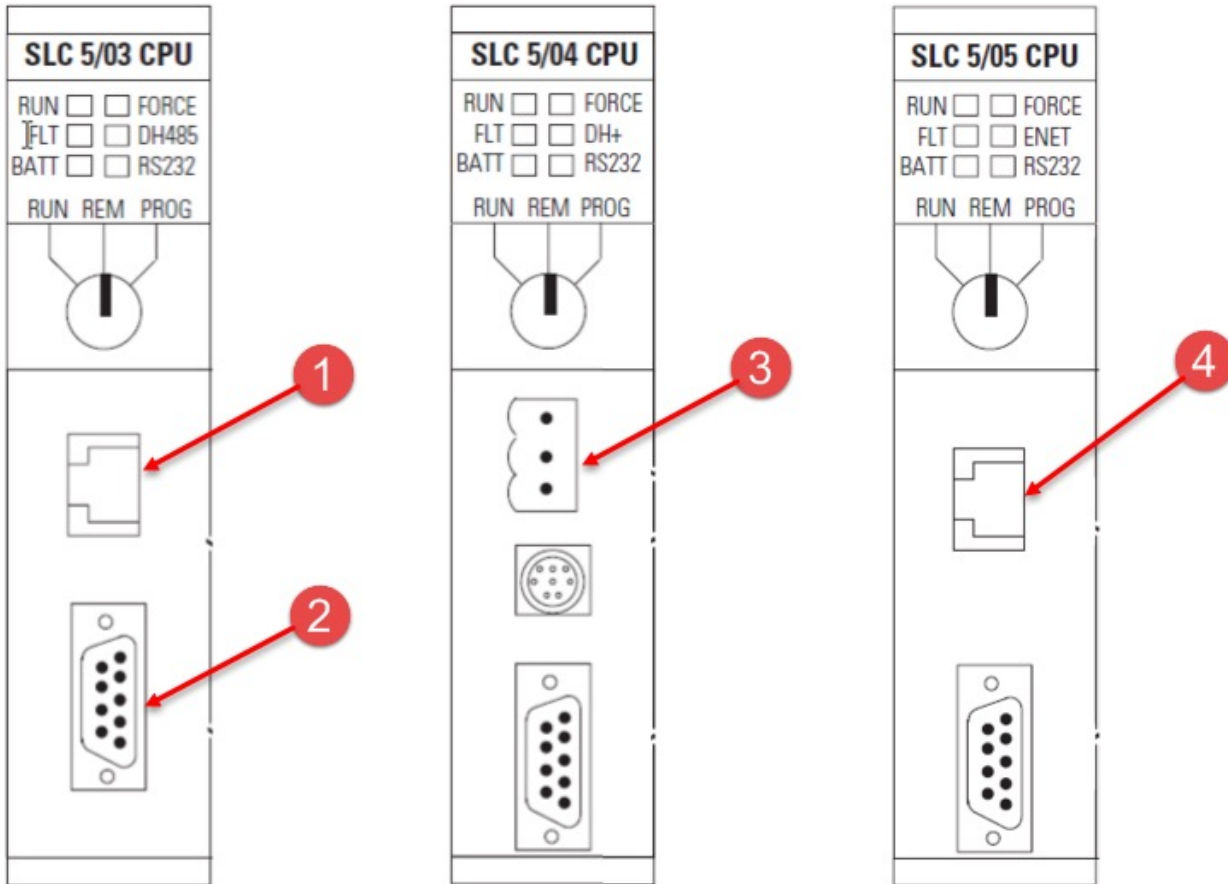

It is important to understand what the port numbers are, as well as their communication method. Here is a graphic of the three processors the students will see in the lab: an SLC-5/03, SLC-5/04 and SLC-5/05.

First realize that the number “2” identifier is a 9 pin, D-shell connector for primarily RS-232 communications. This is always termed Channel 0.

Number “1”, is Channel 1 on the SLC-5/03 processor, which is DH-485 (Data Highway 485 – an older PLC network). The user would use a PIC box interface to connect to this port from the computer.

Number “3”, is Channel 1 on the SLC-5/04 processor, which is a DH+ (Data Highway Plus) network. This network was common on primarily the PLC-5 processors.

Number “4”, is Channel 0 on the SLC-5/05 processor, which is an Ethernet port (high speed) network port. This is the primary method of communications in most PLC installations over the last 5 years.

# Communication Ports on the Processor, cont.

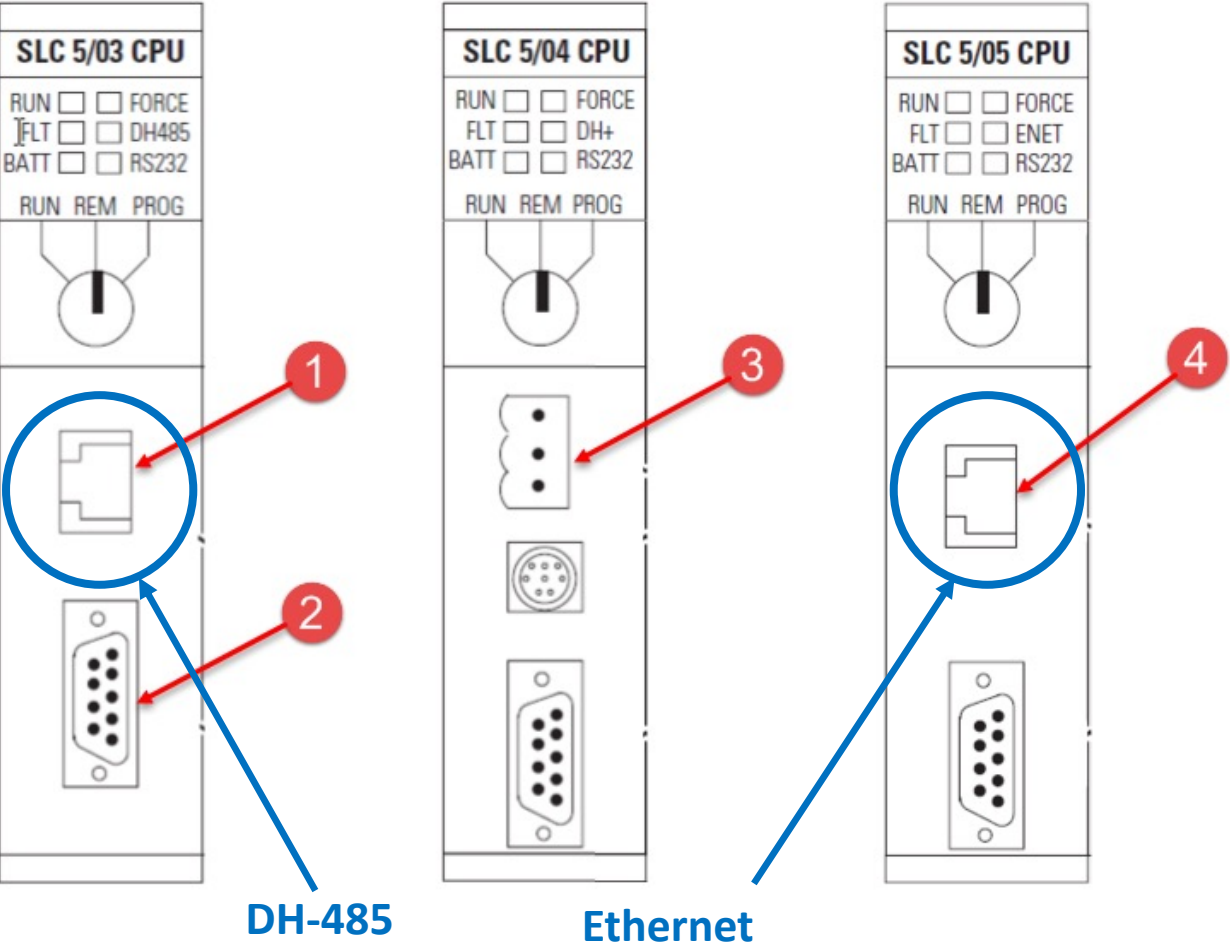

Major Problem:  
Major Confusion:

Allen Bradley messed up years ago when they developed the SLC-5/03 processor. They used an RJ-45 connector, which is a standard connector for Ethernet networks.

A 1747-PIC interface box is used to connect the program panel to the SLC-5/03, Channel 1, DH-485 port.

So basically, when someone sees the RJ-45 connector on the front of the SLC-5/03 processor, they think they can just come out of the Ethernet port on the computer, cable to it, and communicate via Ethernet. It will not work.

Only the SLC-5/05 processor can communicate via Ethernet.



**1747-PIC**



**RJ-45 Ethernet connectors**

# Two types of memory in a PLC processor:

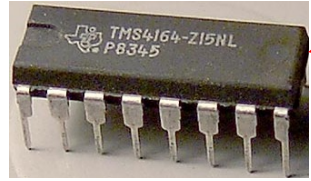

An original IC chip. This is what older memory chips looked like.

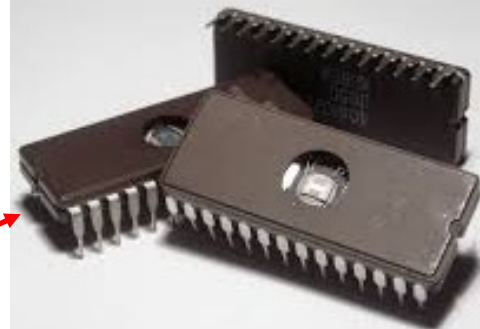

EPROM chips. Window in the top that erased memory with ultra-violet light



These are large scaled integrated memory chips (EEPROM)

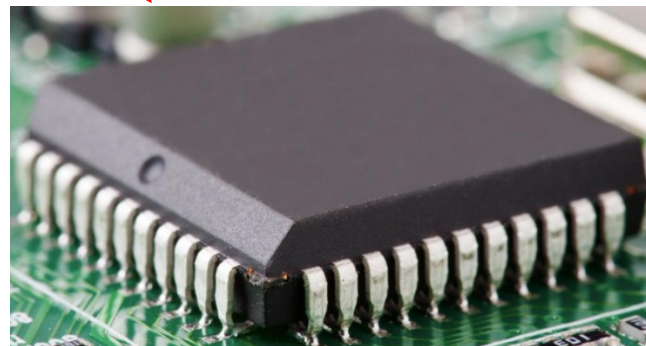

The PLC processor has basically two types of memory: RAM (Random Access Memory), and ROM (Read Only Memory). The RAM is volatile (loses its memory when power is removed), and requires battery backup to retain its memory in case there is a power loss. RAM is where the PLC program is stored.

ROM is non-volatile (keeps its memory when power is lost), and is basically where the operating system of the processor is stored. There are basically three types of ROM:

PROM – Programmable Read Only Memory – which cannot be reused or upgraded.

EPROM – Erasable PROM – which can be programmed, then erased with ultra-violet light, then reused. This may be found on older processors, but not anything within the last 10 years.

EEPROM – Electrical Erasable PROM – which can be erased electrically and reused. This is found in modern day PLC processors. On many PLC processors (including the SLC-5/03, 5/04 and 5/05, the processor operating system can be upgraded to a newer operating system, using a PC computer based application called ControlFlash. Basically this will erase and re-program a EEPROM in the processor that holds the operating system.



# Designation on the Processor:

The label on the side of the processor will designate the type of processor, as well as the version of firmware used in the processor.

The firmware can be upgraded by a software that Rockwell Software uses termed as ControlFlash. This is very common on the ControlLogix platform, but can also be used to upgrade the firmware (Operating System) of an SLC-500 modular processor (SLC-5/03 and above). Upgrading the firmware could mean more advanced instructions that are available in the newer operating system. It could be cheaper upgrading the firmware, rather than replacing the processor with a newer version.

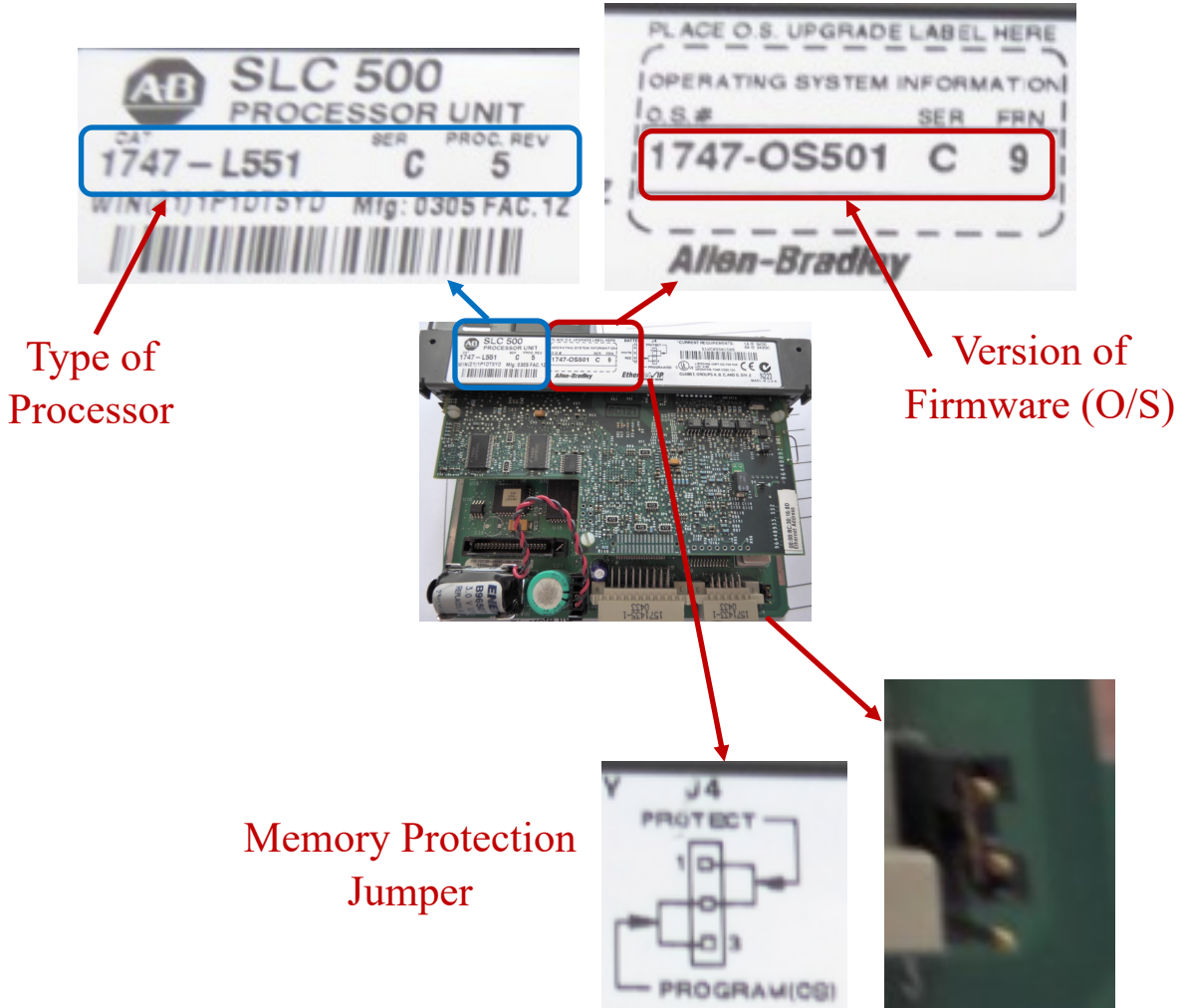

Notice that at the lower right of the processor board is the memory protection jumper. If the connector is connecting the top and middle pins, it will protect the (ROM) memory from being altered. By moving the jumper to the middle and lower pins, the operating system can be upgraded.

# Memory terminology:

A person using PLCs will need to understand these basic memory terms:

**Bit** – stands for Binary Digit. A bit is the smallest amount of memory. It is either a “1” or a “0”.

**Nibble** – this is an old school term, but you may run into it. This is 4 consecutive bits. A nibble will be used when the BCD and Hexi-decimal numbering systems are discussed.

**Byte** – this is 8 consecutive bits. This term was used quite a bit when 8 bit discrete I/O modules were popular.

**Word** – this is 16 consecutive bits. This is a very common term. When a PLC instruction is used, it will take up a word in memory. The illustration to the left shows the output image table. Since there is a 16 point output module in slot 2, this output image table, 1 word in length was automatically created.

Notice the bits are numbered 0-15, which is 16 bits. Also notice the word address: O:2.0. The last digit is 0, and it is not used. So the bit address of bit number 6, is O:2/6.

Offset	15	14	13	12	11	10	9	8	7	6	5	4	3	2	1	0
O:2.0	0	0	0	0	0	0	0	0	0	0	0	0	0	0	1	0

Bit

Offset	15	14	13	12	11	10	9	8	7	6	5	4	3	2	1	0
O:2.0	0	0	0	0	0	0	0	0	0	0	0	0	0	0	1	0

Nibble

Offset	15	14	13	12	11	10	9	8	7	6	5	4	3	2	1	0
O:2.0	0	0	0	0	0	0	0	0	0	0	0	0	0	0	1	0

Byte

Offset	15	14	13	12	11	10	9	8	7	6	5	4	3	2	1	0
O:2.0	0	0	0	0	0	0	0	0	0	0	0	0	0	0	1	0

Word

Offset	15	14	13	12	11	10	9	8	7	6	5	4	3	2	1	0
O:2.0	0	0	0	0	0	0	0	0	0	0	0	0	0	0	1	0

Word Address

Bit Number

# Diagnostic Indicators on the Processor:

Processor Status Indicator	When It Is	Indicates that
BATT (Color: red)	On (steady)	The battery voltage has fallen below a threshold level, or the battery is missing or not connected.
	Off	The battery is functional.
FORCE (Color: amber)	Flashing	One or more input or output addresses have been forced to an On or Off state but the forces have not been enabled.
	On (steady)	The forces have been enabled.
	Off	No forces are present or enabled.
ENET Channel 1 (Color: green or red)	Solid green	The Ethernet port is functioning properly and is connected to an active Ethernet network.
	Flashing green	The Ethernet port is functioning properly, connected to an active Ethernet network, and is transmitting packets.
	Flashing red	A hardware or software fault has occurred and is being reported via a code. Contact Allen-Bradley for assistance.
	Off	No Ethernet connection or processor halted.
RS-232 Channel 0 (Color: green)	On (steady) DF1/Modbus RTU Master/ASCII mode	The SLC 5/05 processor is transmitting on the network.
	Off DF1/Modbus RTU Master/ASCII mode	The SLC 5/05 processor is not transmitting on the network.
	On (steady) DH-485 mode	The Channel 0 Communications Active bit (S:33/4) is set in the System Status file and the processor is actively communicating on the network.
	Flashing DH-485 mode	The processor is trying to establish communication, but there are no other active nodes on the DH-485 network.
	Off DH-485 mode	A fatal error is present (no communication).



This slide will define what the different diagnostic indicators mean on the SLC-500 modular processors. This is an SLC-5/05 processor, so it will have an ENET indicator. If this was an SLC-5/03, this indicator would be replaced with a DH-485 indicator. If this was an SLC-5/04, this indicator would be a DH+ indicator. The most critical indicators to check is the RUN indicator and the FLT indicator. If the machine is not running and the RUN light is off, the processor is in the program mode. If the FLT light is flashing, or solid red, the processor is faulted, and may need to be reset, or replaced.

## SLC 5/05 Status Indicators

Processor Status Indicator	When It Is	Indicates that
RUN (Color: green)	On (steady)	The processor is in the Run mode.
	Flashing (during operation)	The processor is transferring a program from RAM to the memory module.
	Off	The processor is in a mode other than Run.
FLT (Color: red)	Flashing (at power up)	The processor has not been configured.
	Flashing (during operation)	The processor detects a major error either in the processor, chassis, or memory.
	On (steady)	A fatal error is present (no communication).
	Off	There are no errors.

# SLC-500 Modular Processor:

SLC 5/05 Hardware Components

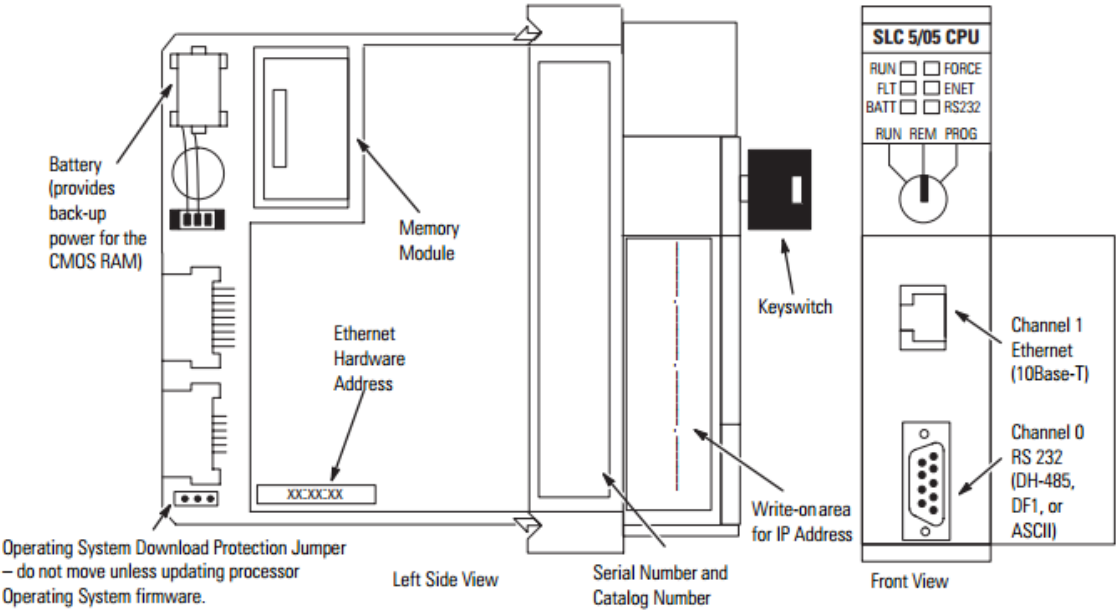

This graphic shows the battery, capacitor and the battery connector on the processor board. First, and most important, to replace the battery on a modular SLC-500 system, the user must shut down the machine, power it down, remove the processor and replace the battery. Most processors have the battery on the front of the processor, so it can be replaced without shutting the system down.

The battery backs up the RAM memory (where the ladder program resides). The designers then added a capacitor across the battery, so that it would hold a charge and keep the RAM memory powered while the battery is replaced. This way the battery can be disconnected (battery connector), and then replaced and plugged back into the circuit board, then put back into the chassis, power up, and run the machine.

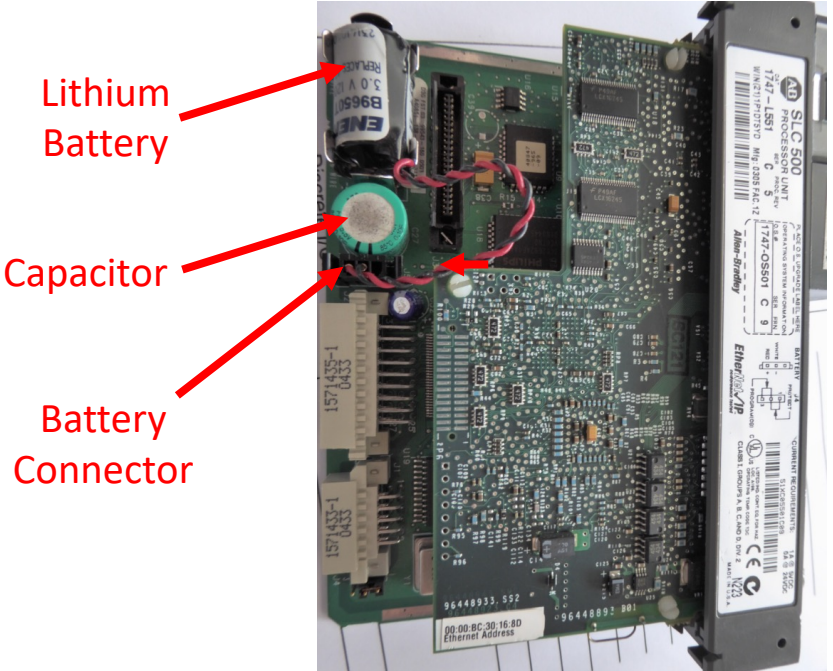

Sometimes the user may hear the term: dump the memory. This is also termed: reset to factory defaults. This will be covered in the next slide, but it does mean that the user will completely reset all the memory within the processor, also clearing out the RAM memory.

# Resetting Processor to Factory Defaults

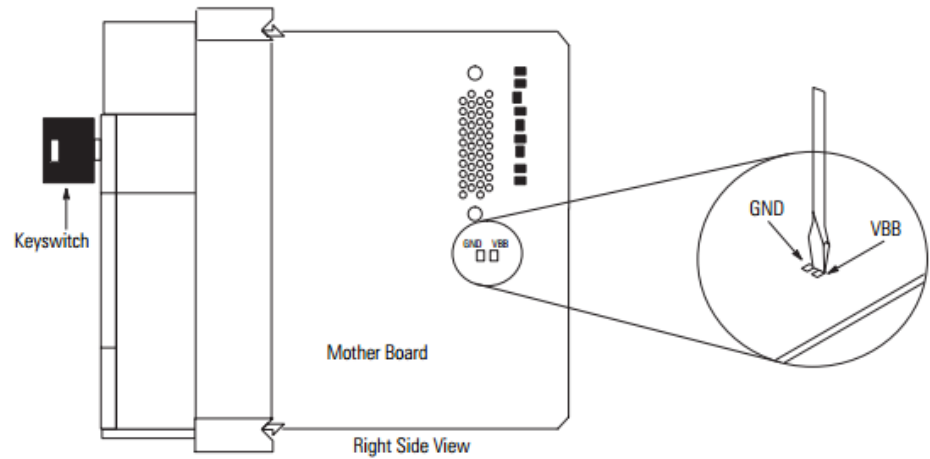

There are times when the user may need to reset the SLC-500 processor to factory defaults. This is also termed dumping the memory of the processor.

A user may choose to do this if the processor fails to communicate through any of the communication ports on the processor. I have also experienced a processor tie up, where it would not recognize part of the I/O chassis. Resetting the processor and re-downloading the program fixed the problem.

First, remove the processor from the un-powered chassis. Make sure you only touch the edge of the printed circuit board, or only the plastic on the edge of the processor (due to static electricity issues).

Unplug the battery.

Short the GND and VBB terminals with a screwdriver.

Reconnect the battery. Insert the processor into the chassis, then power up the unit.

The user will need to download the PLC program to the processor from the program panel.

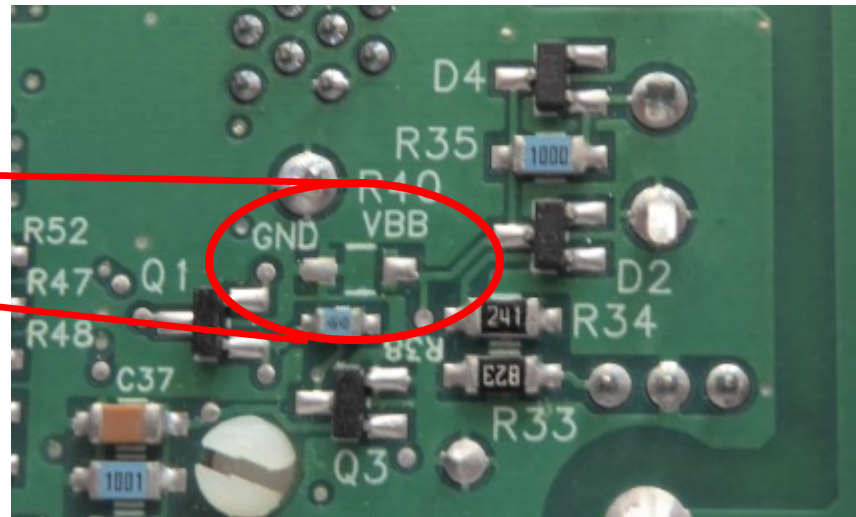
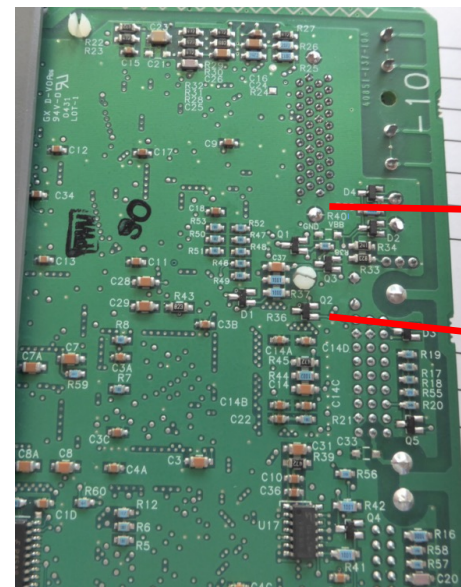

# Processor Parameters: RAM memory size

## Processor General Specifications

The table below lists general specifications for SLC 500 modular processors.

Attribute (1747-)	SLC 5/01		SLC 5/03			SLC 5/04			SLC 5/05			
	L511	L514	L524	L531	L532	L533	L541	L542	L543	L551	L552	L553
Program memory (words)	1 K	4 K	4 K	8 K	16 K	32 K	16 K	32 K	64 K	16 K	32 K	64 K
I/O capacity	3940 discrete		4096 discrete									
Remote I/O capacity	Not applicable		Processor memory and chassis power limit up to 4096 inputs and 4096 outputs									
Chassis/slots, max	3 Chassis/30 Slots of I/O											
Standard RAM	Capacitor - 2 weeks <sup>(2)</sup> optional lithium battery - 5 years  Lithium battery 2 years Capacitor - 30 minutes minimum											
Memory back-up options	EEPROM			Flash EPROM								

The top graphic shows the different RAM memory sizes for the 3 different SLC-500 processors that will be used in this course. A “K” is a 1,024 words of memory. The larger the RAM memory, the larger the ladder program can be. The lower graphic shows a small two rung programs, with numbers of how many words of memory is used to create this program. 11 words are used in just these two rungs of the program. That is 11 words in what will be called the program file, or ladder logic file of the SLC-500.

The RAM memory (Random Access Memory) is also volatile memory. This means that when power is shut off, the memory will lose its content. This is why many PLCs have batteries, so that when the power is shut off, the battery will hold the program in the RAM memory. If the program is lost, due to a power failure, and a dead battery, the program must be reloaded into the processor. This will require the user to get a program panel, setup communications to the processor, and download the program to the PLC processor.

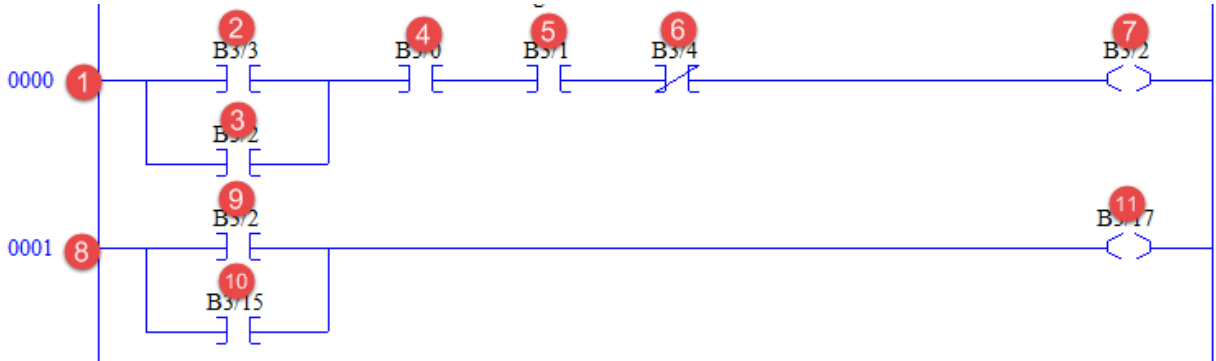

# Processor Scan Times:

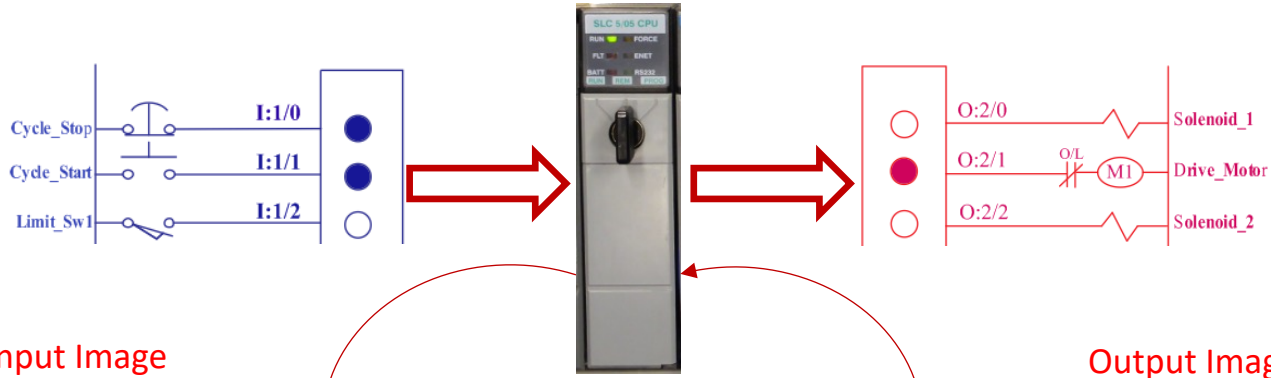

**Input Image Table**

Offset	15	14	13	12	11	10	9	8	7	6	5	4	3	2	1	0
I:1.0	0	0	0	0	0	0	0	0	0	0	1	0	1	0	1	1

**Output Image Table**

Offset	15	14	13	12	11	10	9	8	7	6	5	4	3	2	1	0
O:2.0	0	0	0	0	0	0	0	0	0	0	0	0	0	0	1	0

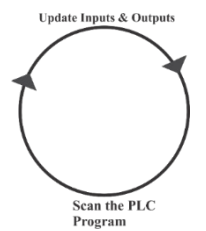

Check for Logic Continuity of XIC

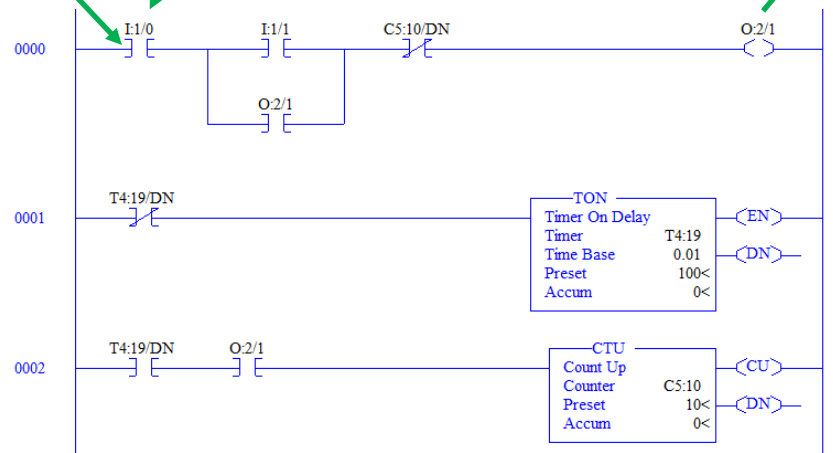

When the SLC-500 processor is put into the Run mode, the scan starts. There are two parts to the I/O scan: **Update I/O** (sometimes called I/O scan) where the processor reads the inputs status, writes it into the input image table (PLC data memory), then writes the data from the output image table to the output module to turn the outputs on and off. On a typical processor, this will take between 0.25 and 2.6 mSec.

**Scan the PLC program**, which is when the processor goes through and checks to see if each instruction (XIC, XIO, OTE, etc.) has continuity. It comes to the XIC I:1/0 in rung 000, then looks at the addressed bit in the input image table, to see if the XIC is true, then it goes to the next instruction. This happens very fast (0.9 – 8 mSec per K of memory (1000 instructions)).

If the scan sees logic continuity to the instructions in a rung that will bring logic power to an output coil (XIO), the scan writes a “1” into the corresponding address in the output image table, then when the scan updates I/O, it will write the “1” to the output module, turning on the actual output device.

# SLC-500 Power Supply:

The Power Supply supplies power to the internal circuitry of the processor and to the I/O modules. Power supplies are purchased as either 24Vdc or 120VAC for the input voltage. This voltage is stepped down to 5V, 15V and 24V, DC to feed the chassis backplane, which operates the electronics in each module. The power supply protects the chassis from over voltage, over current, or transients (spikes).

There is a diagnostic indicator on the PLC power supply. If this indicator is on, the power supply is functioning OK. This should be the 1<sup>st</sup> visual indicator the maintenance person should check when there are problems with the system. If the indicator is off, the P/S fuse could be blown, a lost line feed, an overloaded power supply, or a bad power supply.

The SLC-500 power supply also has made 24Vdc available at its power terminals for any low current application, such as a proximity switch.



Power Supply Diagnostic Light

Small button at base to open P/S door

Line Fuse

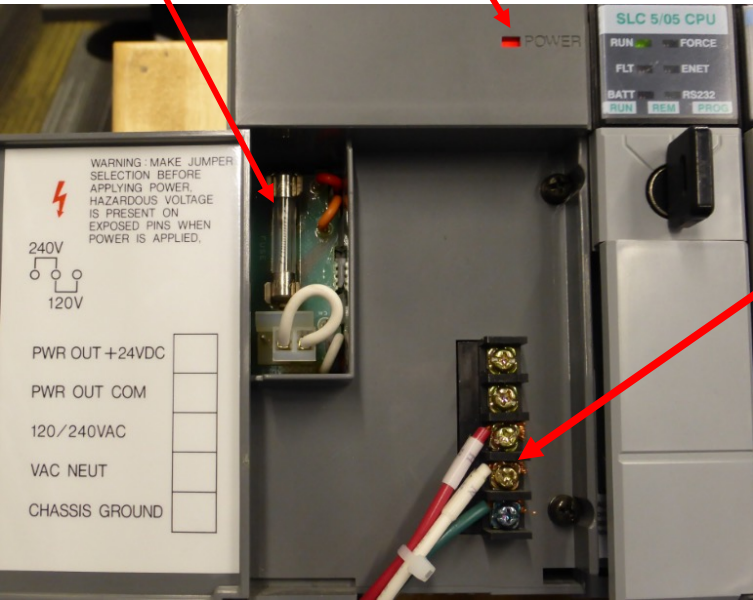

120VAC power feeding P/S



# Input and Output Addressing:

I for Inputs

O for Outputs

Bit Number(0-15)

**I:1/9**

Slot Number

Expanded I/O Address

**O:2.0/9**

Word Number

It is critical to understand how to interpret the addressing of the inputs and outputs on a PLC system.

The SLC-500 uses what is called logical addressing. This means that the address starts with a letter, that is somewhat explanatory of what the address is. An input starts with "I". An output starts with "O". A timer starts with a "T".

A colon ":" is used as a delimiter between the data type, and the slot number.

So the upper left address is the simplified address, which is input or output type, then a colon, then the slot number the module is located in, then a forward slash, then the bit number. The bit number is in decimal, which means it goes from 0-15.

The lower address is an expanded address, which will also display the word number (later on we will see that a word is 16 bits long). If the module is a 32 point module (32 I/O terminals), then it will take two words for the module, which in this case could be O:2.0/0-15, and O:2.1/0-15.

# Fixed I/O unit I/O addressing

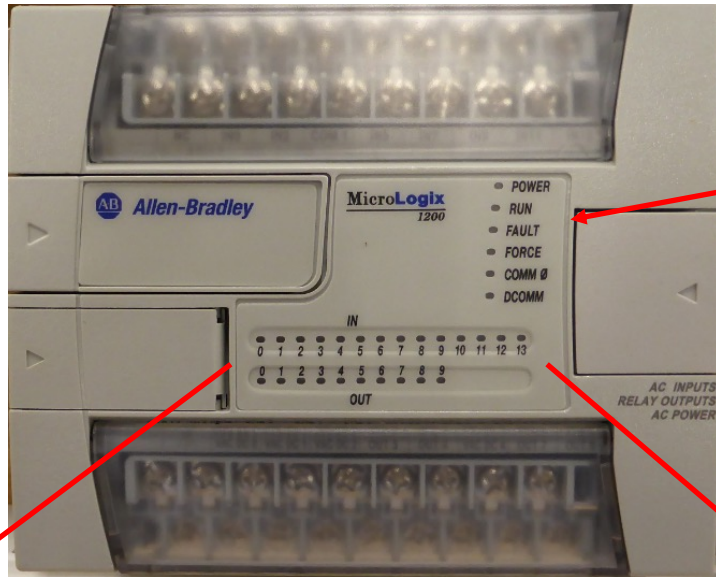

A Micrologix  
1200 fixed  
I/O unit

A MicroLogix 1200 PLC is a fixed I/O unit. Though the unit has the capability of adding some modular I/O to it, for this purpose, we will focus on it just being used as a stand alone unit. Realize that the power supply, processor and I/O are all on this unit (notice the processor diagnostic indicators on the unit). Since the processor is always slot 0, all of the I/O on the fixed unit is considered in slot 0.

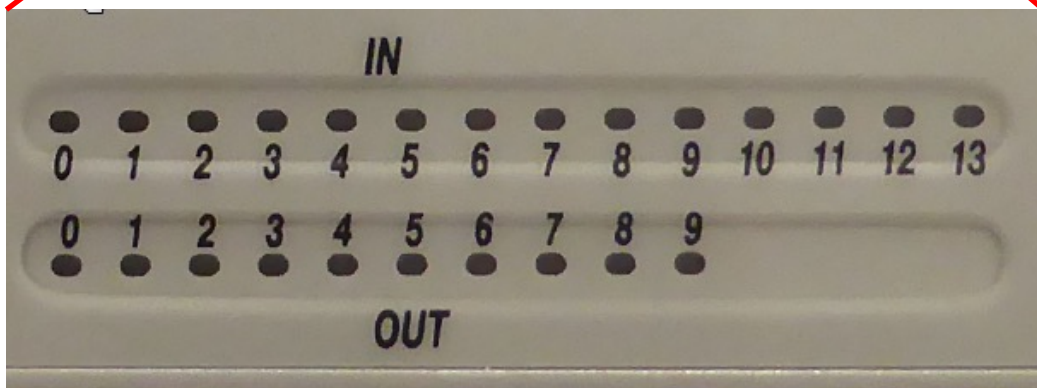

# Fixed I/O unit I/O addressing, cont.

On this MicroLogix 1200 unit, there are 14 inputs (0-13), and 10 outputs (0-9).  
The input address shown as I:0/10, means it is an input, in slot 0, and it is terminal 10.  
The output address shown as O:0/4, means it is an output, in slot 0, and it is terminal 4.

One fact that is important to understand, is that each of these lights/terminals are considered a bit (binary digit) in memory. Also, a Word in memory has 16 bits. The addresses shown can also be displayed with the programming software as O:0.0/4 and I:0.0/10. This can be sort of confusing, but there is a reason for this. If a fixed I/O unit has 20 inputs, and 12 outputs, the first 16 bits of the inputs would be I:0.0/0-15, the next 4 bits would be displayed as I:0.1/0-3.

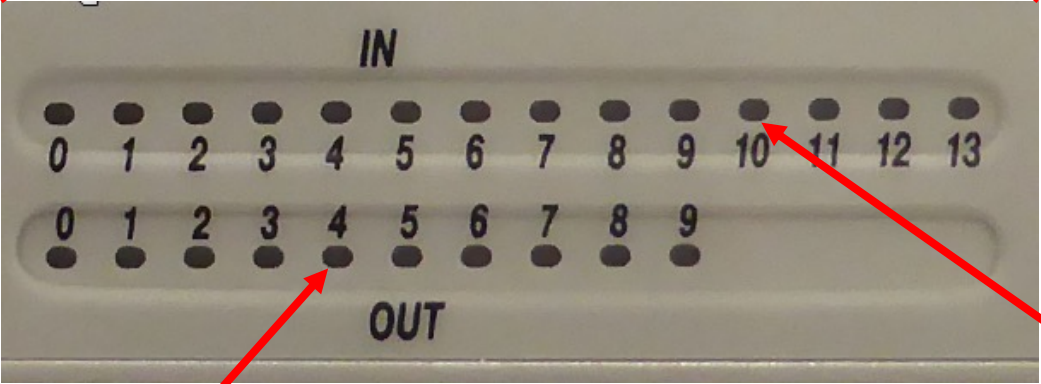
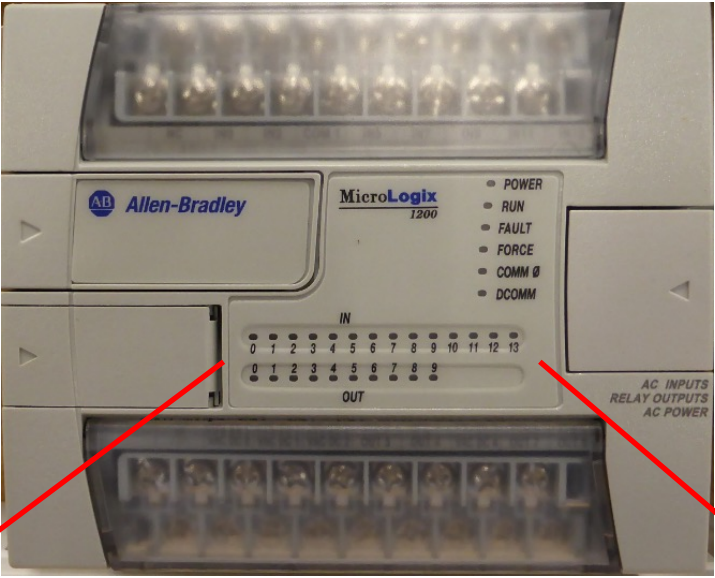

**O:0/4**

**I:0/10**

# SLC-500 I/O Addressing

Slot Number:      0      1      2      3      4      5      6



I:1/9

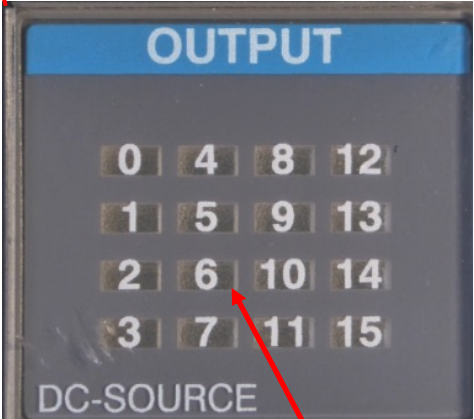

O:2/6

The modular I/O addressing is based on where the I/O module is located. Notice that this is a 7 slot I/O chassis. Allen Bradley also makes a 4, 10 and 13 slot chassis for the SLC-500 system.

The 16 point input module is located in slot 1.  
The 16 point output module is located in slot 2.  
This will define their addressing.

The input address shown in the lower left is I:1/9, which means it is an input, in slot 1, and it is terminal 9.  
The output address shown in the lower right is O:2/6, which means it is an output, in slot 2, and it is terminal 6.

The SLC-500 uses what is termed decimal addressing (0-9) for the I/O addresses. This is compared to the PLC-5 (big brother to the SLC-500), which has the bits addressed as octal (0-7), which means there are no 8s and 9s. We will review this addressing later in this course.

The term DC-Sink and DC-Source on the modules will be discussed later in the course. What is important now is to understand basic addressing so you can do the labs.

# SLC-500 I/O Addressing, cont.

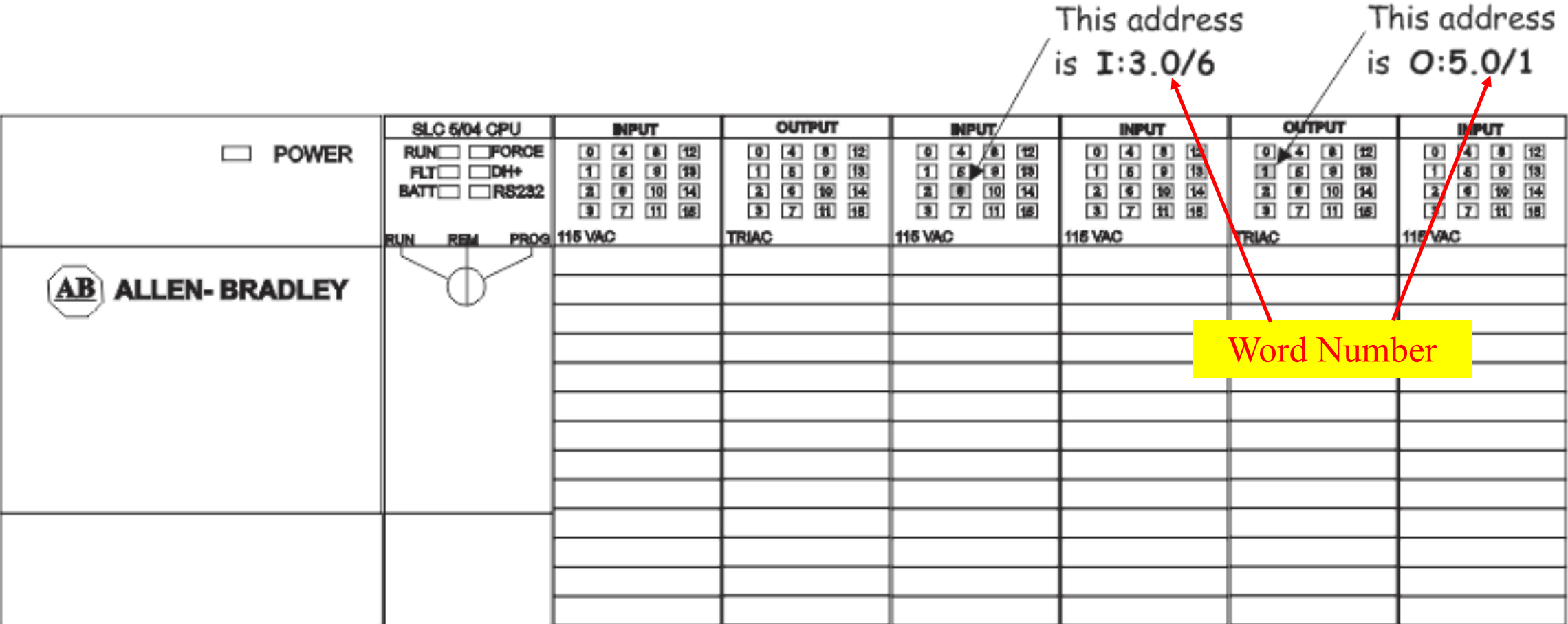

This illustration shows a different I/O placement than what is found on the trainers in the lab. These are 120V modules. Notice that on the output modules, the term TRIAK is used. This is a solid state switching device. Either the modules are Triac or Relay (actual relay contact). The addresses shown are a little different from what we saw on the last slide. The programming software may display the addresses this way as well (the user can change the way they are displayed). The word is shown in the address. Realize that if there was a 32 point module (which is not used too often), there would be 2 words needed (word 0 and word 1). I explain this just to minimize confusion on how the address is displayed.

# Practice Question #1

- In this diagram, what communication method is number 2?
  - a. DH-485
  - b. DH+
  - c. Ethernet
  - d. RS-232

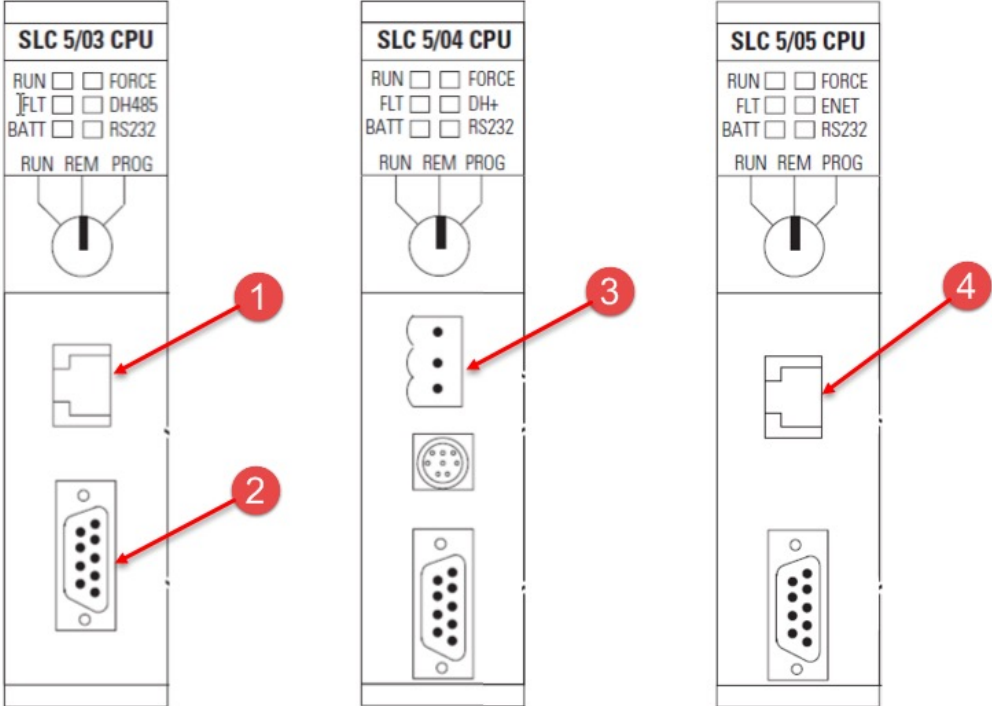

# Answer for Practice Question #1

- In this diagram, what communication method is number 2?
  - a. DH-485
  - b. DH+
  - c. Ethernet
  - d. **RS-232**

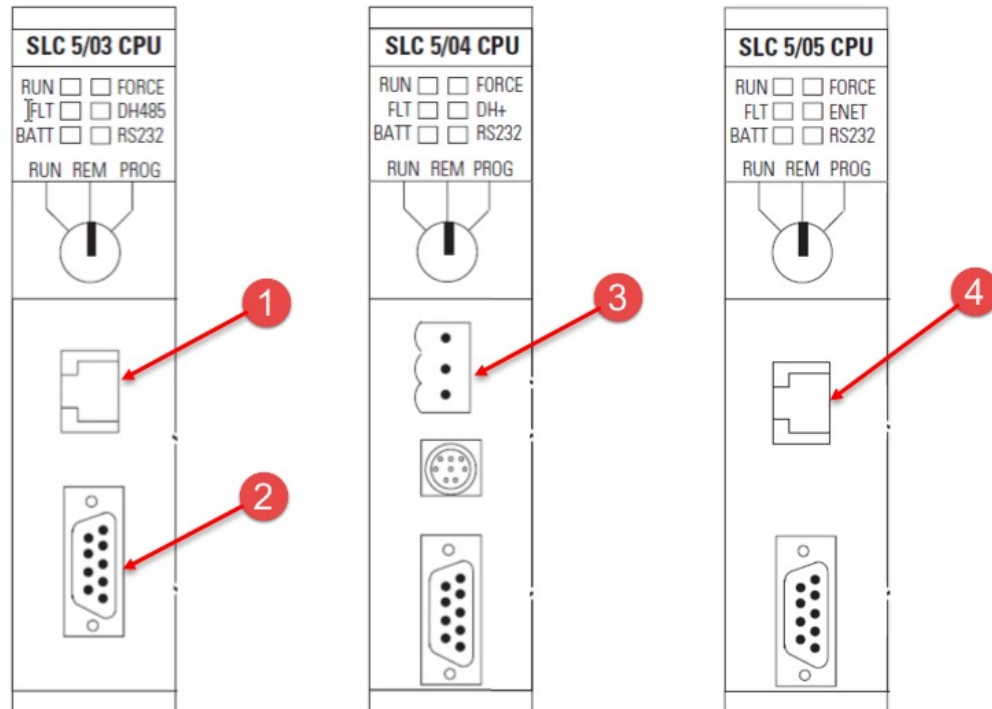

Each processor has a 9-pin, D shell port that will be used for RS-232 communications. This port is termed as Channel 0.

#1 is DH-485 (Thought it is an RJ-45-Ethernet connector)

#2 is DH+

#3 is Ethernet (RJ-45 Ethernet Connector)

# Practice Question #2

- Which of the following terms will have 16 bits?
  - a. Nibble
  - b. Byte
  - c. Word
  - d. ASCII



# Answer for Practice Question #2

- Which of the following terms will have 16 bits?
  - a. Nibble
  - b. Byte
  - c. **Word**
  - d. ASCII

A Nibble has 4 bits.

A Byte has 8 bits.

A Word has 16 bits.

ASCII – stands for American Standard Code for Information Interchange. This is used for sending characters from one device to another.

Offset	15	14	13	12	11	10	9	8	7	6	5	4	3	2	1	0
0:2.0	0	0	0	0	0	0	0	0	0	0	0	0	0	0	1	0

Word



# Practice Question #3

- What is the address of the circled bit?
  - a. O:1/12
  - b. O:2/12
  - c. I:1/12
  - d. I:2/12

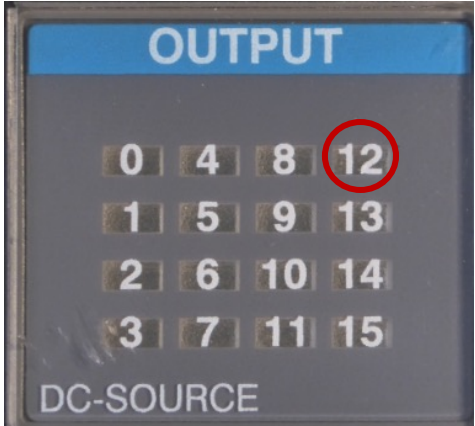

# Practice Question #3

- What is the address of the circled bit?
  - a. O:1/12
  - b. **O:2/12**
  - c. I:1/12
  - d. I:2/12

The output module is in slot 2, thus the address is: O:2/12.

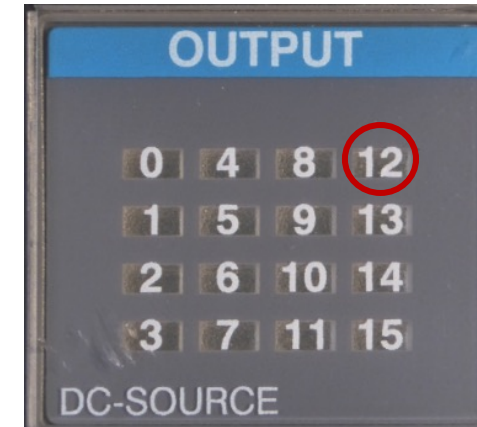

# This Concludes this Instructional Document

## **DOL DISCLAIMER:**

This product was funded by a grant awarded by the U.S. Department of Labor's Employment and Training Administration. The product was created by the grantee and does not necessarily reflect the official position of the U.S. Department of Labor. The Department of Labor makes no guarantees, warranties, or assurances of any kind, express or implied, with respect to such information, including any information on linked sites and including, but not limited to, accuracy of the information or its completeness, timeliness, usefulness, adequacy, continued availability, or ownership.



This work is licensed under a [Creative Commons Attribution 4.0 International License](https://creativecommons.org/licenses/by/4.0/).