

Practice Quiz, 1/2/18:

1. **T F** The input status indicator on a discrete PLC input module is turned on, when a “high” or “on” signal is sent into the input terminal that has the same address as the indicator light.

Explanation: A typical discrete input module has 16 input terminals. Each input terminal has a status light that will turn on, if an “on” signal is present on the input terminal. If a normally open pushbutton is wired to the input terminal addressed as: I:1/1, then the corresponding light will turn on if the pushbutton is actuated (pushed). Most applications are “logic true high”, which means that 24Vdc or 120Vac at the input terminal is a “high”, or “on” signal. Later in the course we will discuss “logic true low” type of input modules, where a 0V signal at the input terminal will be an “on” signal that will turn on the light.

2. **T F** 24VAC is a common industrial control system voltage.

Explanation: Though there are multiple voltages that are used in industrial control systems, there are two that are predominant: 24Vdc and 120Vac. 24VAC is typically a voltage found in residential heating and cooling system controls. Many legacy control systems are 120Vac, that has a control transformer with the secondary wired as 120Vac and all the PLC modules and starter, contactor, and relay coils would be 120Vac. A 24Vdc is the most popular for new installations, and will require not only the transformers, but also a DC power supply that will be used to power the controls circuit. There are still other voltages used in industrial controls systems, such as 5 Vdc (TTL modules), 12 Vdc, and 15 Vdc, but the who control system is not this voltage. Also notice that these are all DC voltages.

3. **T F** When an Allen Bradley SLC-5/04 processor goes into Program Mode, all the discrete outputs are disabled.

Explanation: Most legacy PLCs, including the Allen Bradley SLC-500, PLC-5 and MicroLogix, will disable the outputs if the processor goes into the Program Mode (or Remote Program Mode). Since the scan is shut off in the program mode, the PLC does not want to take the chance of an output remaining on, when it should be turned off, so they simply disable them. When the processor is put into the Run, or Remote Run mode, the scan starts and the PLC outputs are enabled. So they will operate based on the ladder logic program within the processor. The term Test Mode is unique to the Allen Bradley. In this mode, the processor still scans the program, but the outputs are disabled, so they cannot turn on while testing a new program. The test mode is used primarily by program designers. The program panel must be online to the processor, and the key switch on the processor is in the REM position, in order for a user to put the processor into the Test Mode.

4. T F The mode of the processor (program or run) on an SLC-500 modular processor can be changed by the program panel no matter what position the key switch is in.

Explanation: The program panel for an SLC-500 (which consists of a PC computer with the RSLogix500 and RSLinx software) can change the mode of the processor while the program panel is online to the processor, only if the key switch on the processor is in the REM (Remote) position. The RUN position of the key switch will put the processor in the Run Mode. The PROG position of the key switch will put the processor in the Program Mode (which will shut down the machine it is running). The REM position will allow the program panel to change the processor mode to Remote Run, Remote Test or Remote Program.



5. Which one of the following key switch positions would shut the machine down, that this processor is controlling, if the machine is currently running.

- a. 1
- b. 2
- c. 3
- d. None of the positions would shut the machine down

Explanation: Currently the RUN light is green, and the processor key switch is in the REM position, which means the processor is in the Remote Run mode. If the key switch is moved to the RUN position, the machine will keep running. If the key switch is moved to the PROG position, the processor will go into the Program mode, and the machine will shut down. If an SLC-5/05 processor is put into the Program or Remote Program mode, the discrete outputs are disabled, which means none of the starters, contactors, solenoids or pilot lights connected to the

discrete output modules will work, thus the machine will stop working. The processor scan stops when the processor is put into the Program Mode.

6. Which of the following processor modes on an SLC-500 will turn the processor scan on?
- Run Mode
 - Remote Run Mode
 - Remote Test Mode
 - All of the listed options**

Explanation: The processor scanning process starts when the processor is put into the Run mode, or the Remote Test mode. The Run mode and Remote Run mode work the same way. The only difference is the key switch position on the processor. The Remote Test mode is a mode the RSLogix500 software will put the processor into, if the key switch is in the REM position, and the program panel is online to the processor. The user can navigate to the RSLogix500 menu to put the processor into the Remote Test mode. In the Remote Test mode, the processor scans and the output are disabled. The output instructions in the program will highlight so the user can test the operation of the program, but the outputs will not come on, avoiding any possible hazard on the machine.

7. **T F** A discrete output, and the corresponding output status light are both turned on when the bit with the same address in the output image table turns on.

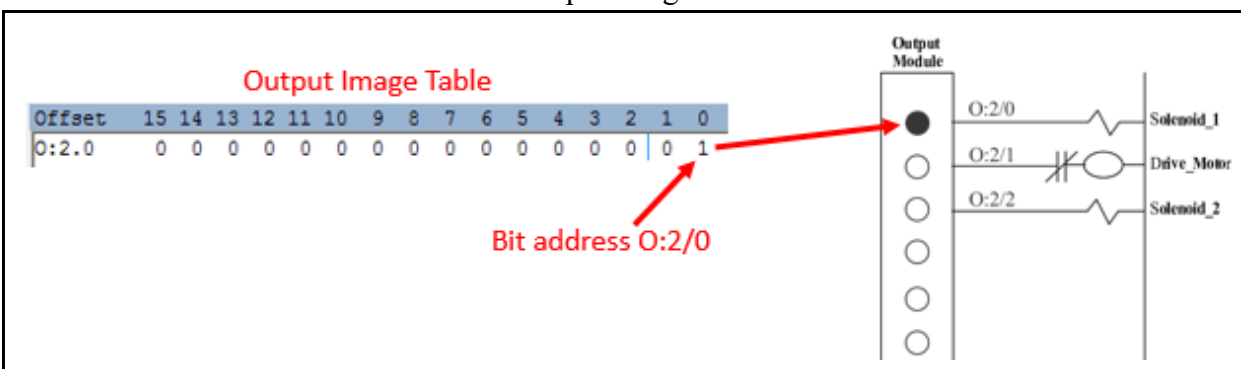

Explanation: When the ladder logic program turns on an output coil in the program, the corresponding bit in the output image table goes to a “1”. When the processor updates the I/O in the scan process, this bit turns on the output and the indicator light with the same address. It is important to understand this concept for tracing down a problem in a PLC based system.

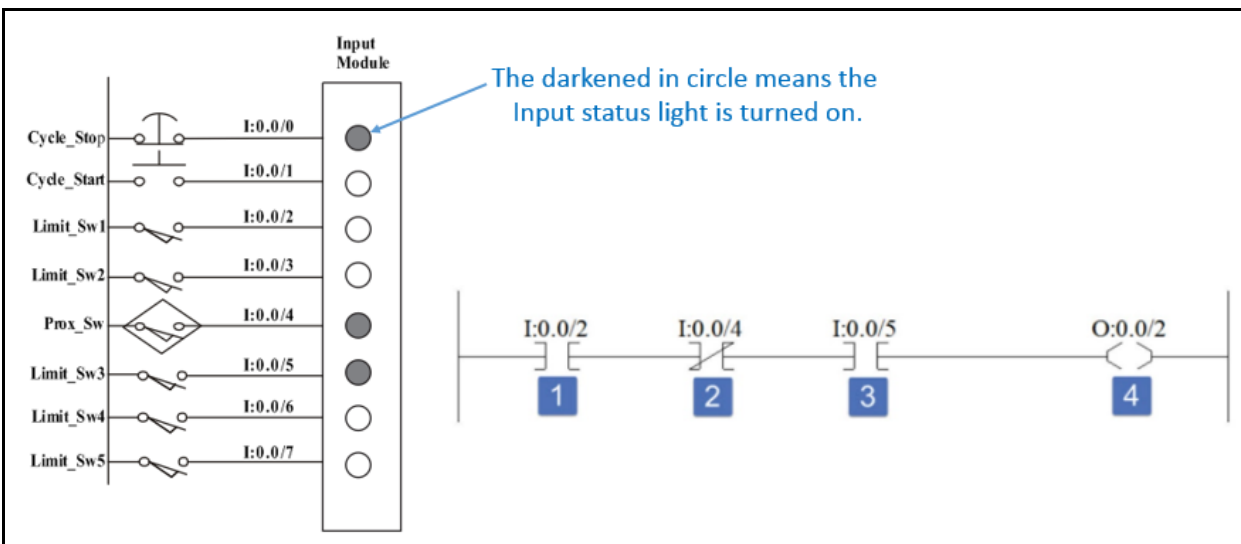

8. Based on the status of the input status lights on the discrete input module, and the rung of logic from a PLC program, which instructions in the rung of logic will have highlight (logic power flow)?

- a. 1
- b. 2
- c. 3
- d. 4
- e. 2 and 3

Explanation: Realize that an XIC instruction (normally open) will have highlight when what it is referenced from is turned “on”. An XIO instruction (normally closed) will have highlight when what it is referenced from is turned “off”. Since number 3 is an XIC instruction, and the address is I:0.0/5, and the corresponding input for I:0.0/5 has the input light on, the XIC will highlight. Number 2 option is an XIO (normally closed) instruction with an address of I:0.0/4. Since the corresponding input light is “on”, the instruction is not highlighted. Number 1 option is an XIC (normally open) instruction with an address of I:0.0/2. Since the corresponding input light is “off”, the instruction is not highlighted.

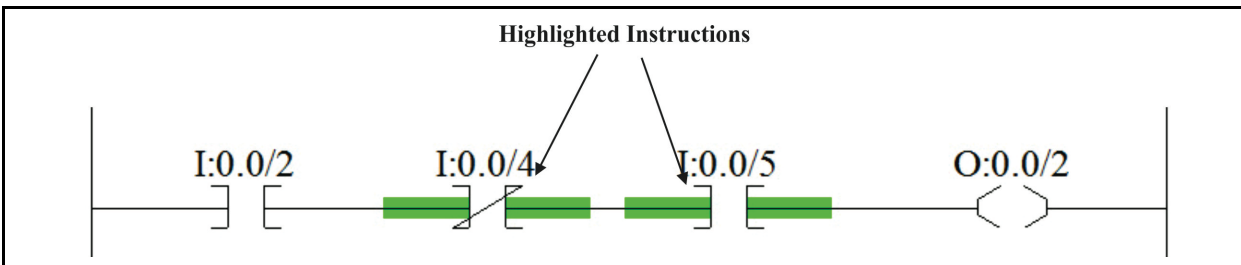

9. T F While viewing the PLC program online with the programming software, the highlighted instruction means that the instruction is disabled and will not be scanned.

Explanation: A highlighted instruction within the PLC program means that the instruction will pass logic power flow. In this graphic, if all three input type of instructions (normally open &

normally closed) are highlighted, then the output instruction (coil) addressed as O:0.0/2 will be highlighted and turn on.

10. T F The first status indicator light a Technician should check if a machine shuts down is the Battery light on the processor.

Explanation: The first indicator light to check should be the RUN light. If the RUN light is not on, then the processor is shut down and thus the machine is shut down. If a machine shuts down, the machine could have been put into Program mode, which shuts down the scan. The machine could have been stopped because an operator pushed a cycle stop, or E-Stop pushbutton. In this case, the processor is still running. The most concerning shut down is if a fault occurred. The FLT indicator light on the processor would be flashing. In module 5 of this course, the student will learn how to respond to processor faults.

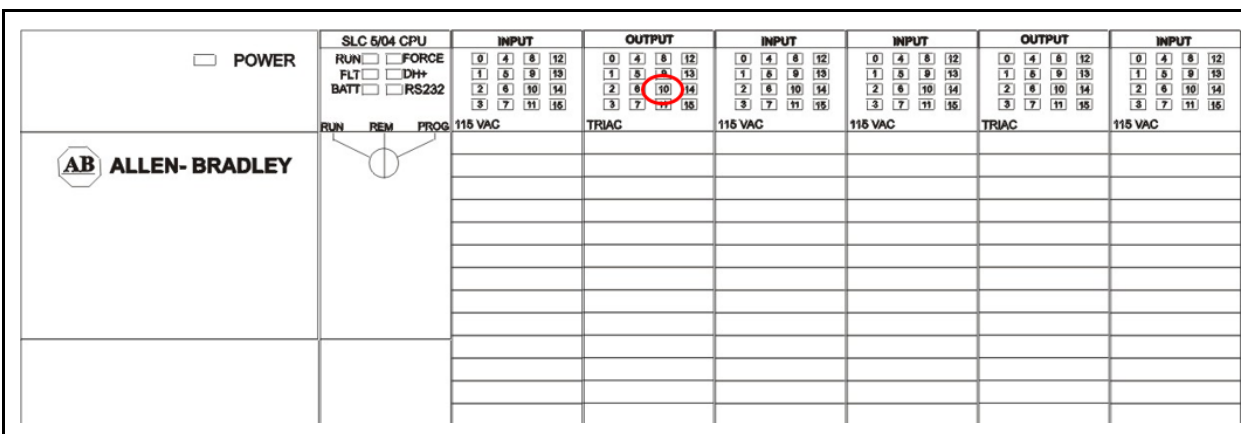

11. What is the address of the circled bit on this SLC-500 modular chassis?

- a. I:1/10
- b. I:2/10
- c. O:1/10
- d. **O:2/10**

Explanation: In this chassis, the processor is located in slot 0, the first input module is in slot 1, and the output module that has the circled bit is in slot 2. So an output module in slot 2, and bit 10 is addressed as: O:2/10, or sometimes in the software it is O:2.0/10.

12. Which type of memory in the PLC processor, is the PLC program (ladder program) stored in?

- a. ROM
- b. EEPROM
- c. EPROM
- d. **RAM**

Explanation: RAM stands for Random Access Memory. This is the memory that stores the PLC program, data files, and other data needed to run the machine the PLC is controlling. The

amount of RAM memory that a processor has will determine the size of the PLC program. Many of the SLC-500 modular processors in the PLC lab are 16K of memory, which is roughly 16,000 words of memory. Every relay type instruction (XIC, XIO, OTE, etc) uses a word of memory. So a rung with 10 of these instructions in series will use 10 words of memory. So a complicated program with 2000 rungs of logic will take a larger processor memory than a program with 200 rungs of logic for the program.

13. T F A modular type of SLC-500 processor (SLC-5/04 or SLC-5/05) can be located in any slot in the I/O chassis.

Explanation: A modular type of SLC-500 processor must always be located in the left most slot of the I/O chassis. This slot is numbered slot 0.

14. T F The RS-232 port on the front of a modular SLC-500 unit is identified as Channel 1.

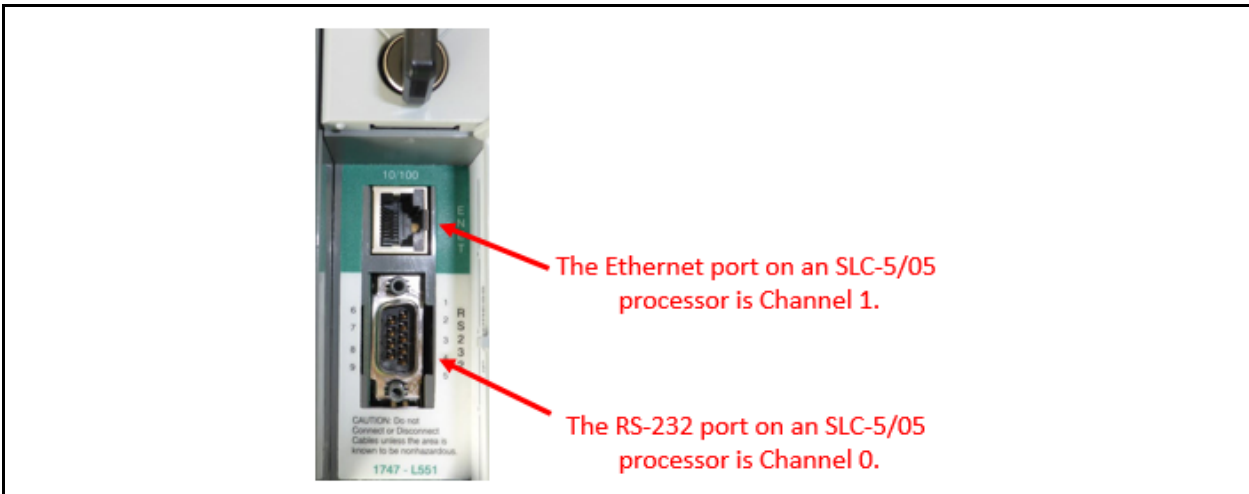

Explanation: On any of the modular type of processors: SLC-5/03, SLC-5/04 and SLC-5/05, the RS-232 port is always Channel 0, and the other port on the processor is Channel 1.

15. T F The way that the input and output devices are wired to the I/O modules, will determine which inputs (when activated) will turn on a specific discrete output.

Explanation: The PLC program (ladder program) will determine which inputs will turn on specific discrete outputs. Realize that the PLC program has to be created by a Control Designer. When the PLC is purchased, the RAM memory is empty. A PLC program must be created that will run a machine, based on a sequence of operation created by the machine design team. This information is then turned over to the Control Designer, and this person will create the ladder logic program that will run the machine. There are other programming languages that the

program can be created in, such as statement language and function block programming, but ladder is still the most popular at this time.

16. Which one of the listed devices is not a discrete I/O device?
- a. Pilot light
 - b. Limit switch
 - c. Thermocouple**
 - d. Pressure switch
 - e. Solenoid

Explanation: A discrete I/O device is an on/off device. This means the device has two state: on and off. Examples of discrete devices are pushbuttons, switches, solenoids, motor starters, contactors, etc. Examples of analog devices are: thermocouples, RTDs, thermistors, and many other types of sensors. Analog is variable, and discrete is on or off.

17. **T F** The PLC power supply, supplies low voltages to the I/O chassis backplane to make sure that the processor and I/O modules have the correct internal voltages to operate correctly.

Explanation: The PLC power supply not only supplies the internal operating voltages for the processor and I/O modules, it also protects from overvoltage or undervoltage conditions. There is usually a diagnostic indicator right on the power supply. If the light is on, the power supply is working properly. Many power supplies have a line side fuse mounted on the unit. An important aspect to remember is that the RAM memory inside the PLC that holds the PLC program is volatile. This means that when the power is shut off, the processor loses the PLC program (It then would have to be reloaded from the program panel). A battery is typically used within the processor to hold the program if power from the power supply is lost. As long as there is power from the power supply, the PLC program held in the RAM will not be lost.

18. **T F** RSLinx is the name of the computer application that will be used to create the ladder logic program, load the program into the PLC processor, and monitor the program online.
- Explanation: RSLinx is the communication application created for Allen Bradley controllers, that will link communications from the PLC processor to the Windows (operating system) environment. RSLogix500 is the programming software created by Allen Bradley to create the PLC program, load it to the PLC (via RSLinx communication software), and monitor the program online. Realize that download (sending the program to the processor) and going online with RSLogix500, will require communications between the PLC processor and the windows operating system. This will require that a communication driver is created in RSLinx, in order to have a pathway for this communication.

19. T F During a PLC processor scan, the processor scans the ladder program and updates the I/O, which means the status of the input modules is written into the input image table, and the output image table data is written out to the PLC discrete output modules.

Explanation:

20. Which one of the following I/O addresses would indicated to the user, that the I/O device is wired to a fixed I/O PLC system, such as a MicroLogix 1200?

- a. I:1/5
- b. O:2/10
- c. **O:0/3**
- d. I:4/12

Explanation: This address shows a “0” for the slot number. A fixed I/O PLC will have inputs, outputs and processor on the same unit. The MicroLogix1200 that is used in the Industrial Electrical II course is this type of PLC. Any I/O on an Allen Bradley fixed I/O type of PLC system will have the I/O that is wired to the base unit addresses as slot 0. So the I/O addresses may be I:0/4 and O:0/6 as an example. A modular type of SLC-500 system has the processor mounted into slot 0, so there cannot be any I/O addressed for slot 0.

Also realize that a fixed I/O unit, many times will have the capability of having an expansion rack added to the fixed unit. This will start with slot number 1, so the I/O addresses many then look the same as a full modular SLC-500 system.

21. T F A driver in RSLinx with the default name of AB_DF-1, DH-485, would typically mean that the communications will be serial, as RS-232.

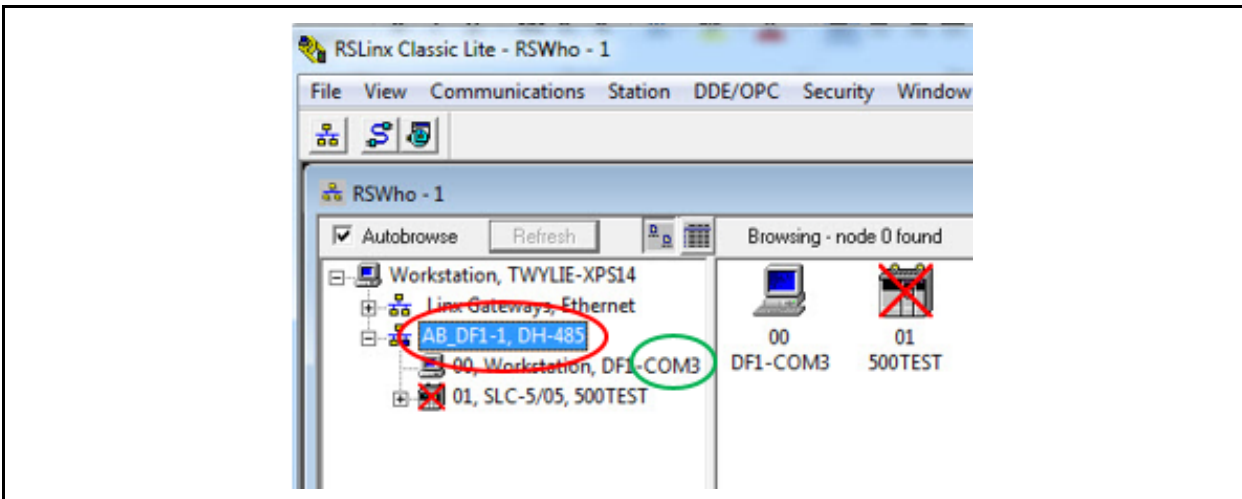

Explanation: The AB_DF-1, DH-485 is the default name for the RS-232 driver that the students will configure in the lab, in order to connect the computer to the PLC processor. Notice that the driver name is within the red oval of this graphic. Also notice that within the green oval, the communications will be with COM3 of the computer. Another thing to notice about this graphic is the red “X” over the processor that has the name of 500TEST. This means that at one time

there was communication with this processor, but now there is no communication. This indicates a communication error.

22_ While configuring an RS-232 driver in RSLinx, what command is used to have the COM port baud rate synchronize with the Channel 0 port baud rate on the SLC-500 processor?

- a. Add New
- b. Synchronize
- c. Baud Detect
- *d. Auto Configure

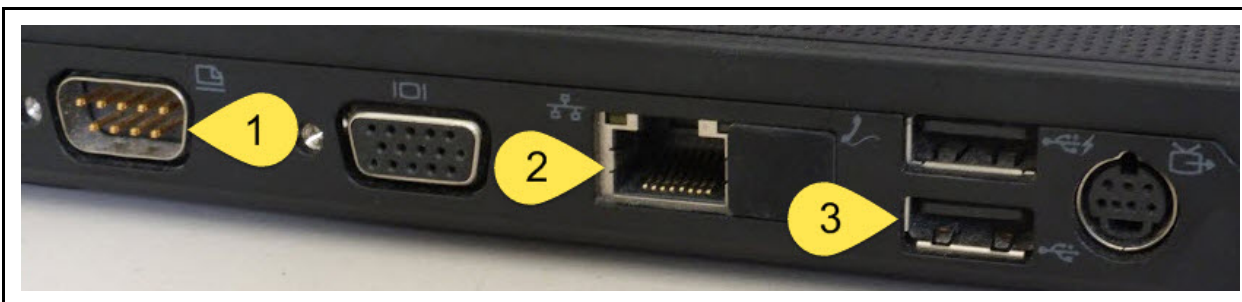

23. The communication port on a computer that is designated with the number “2” in this graphic is a(n):

- a. Serial port
- b. Parallel port
- c. USB port
- d. Ethernet port**

Explanation: Number 1 is the RS-232 (COM1) port of the computer. Number 2 is an RJ-45 connector, which is a standard Ethernet port. Number 3 is a USB port.

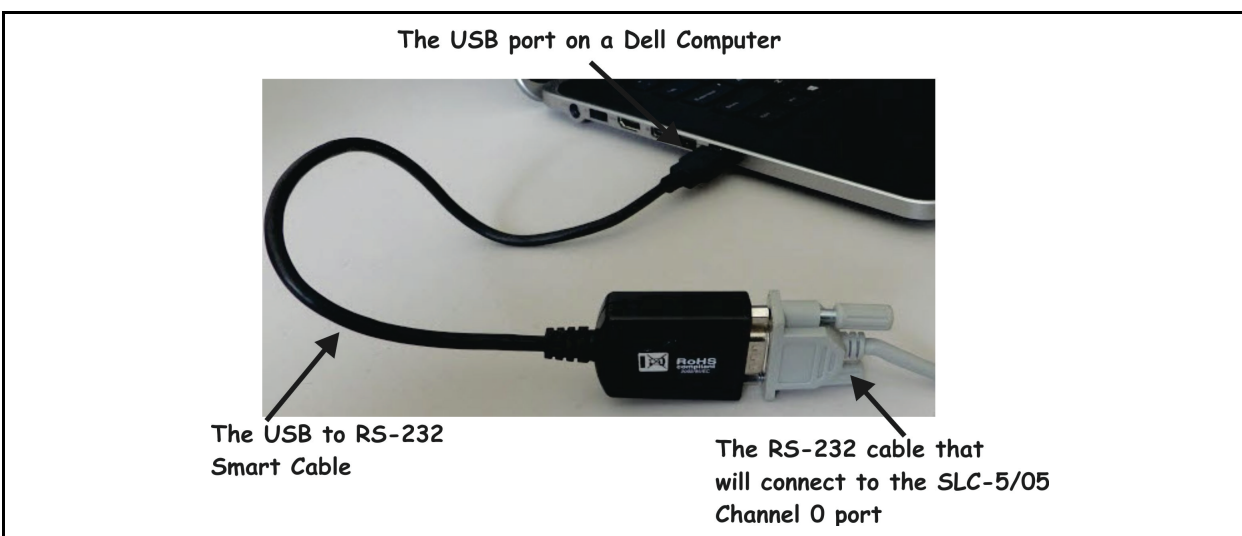

24. T F If a smart cable is used to convert the USB to RS-232 to communicate with an SLC-5/05 processor, the cable is automatically configured by the operating system to perform the communications.

Explanation: Since most laptop computers do not come with RS-232 ports, a smart cable must be bought that will change USB to RS-232. In order to make this cable work, the user must download the device driver from the manufacturer's website. The computer will assign a COM port to the USB port. This COM port must be specified in RSLinx when the communication driver is created.

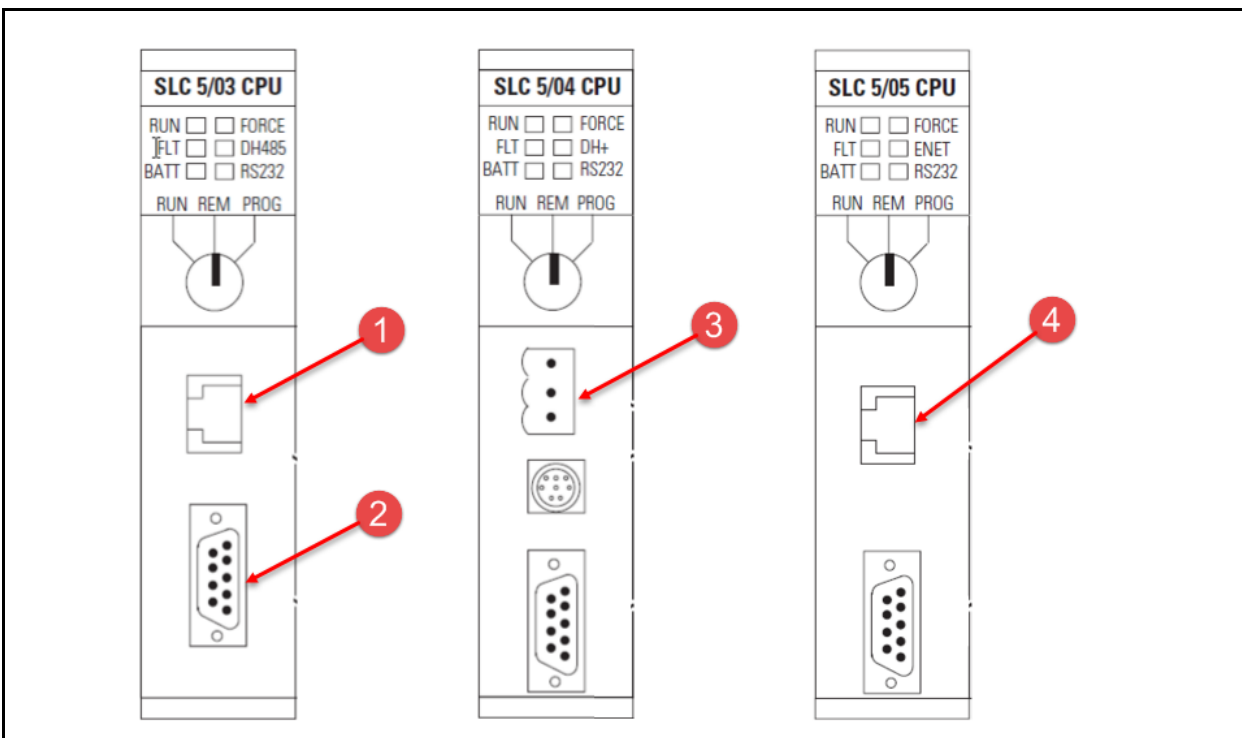

25. T F The communication port designated as number “1” is an Ethernet port.

Explanation: This is a very confusing concept, but it is actually a mistake by Allen Bradley. The RJ-45 connector is a standard Ethernet connector. On the SLC-5/03 processor (left most) the RJ-45 connector is used for DH-485 (a slow serial network). The same connector on the SLC-5/05

(marked as number 4) is an actual Ethernet port. On all three of the modular processors the “D” shell connector is the RS-232 port and is identified as channel 0. The DH-484 port (marked as number 1) on the SLC-5/03 processor is Channel 1 port. On the SLC-5/04 processor, Channel 1 is a DH+ (Data Highway Plus) port (marked as number 3). This is a fairly fast communication method that is used in many legacy installations. Channel 1 on the SLC-5/05 processor (marked as number 4) is the Ethernet port.

26. **T F** An XIO (N.C.) instruction will show highlight when the bit that is assigned to it is a “0” or off.

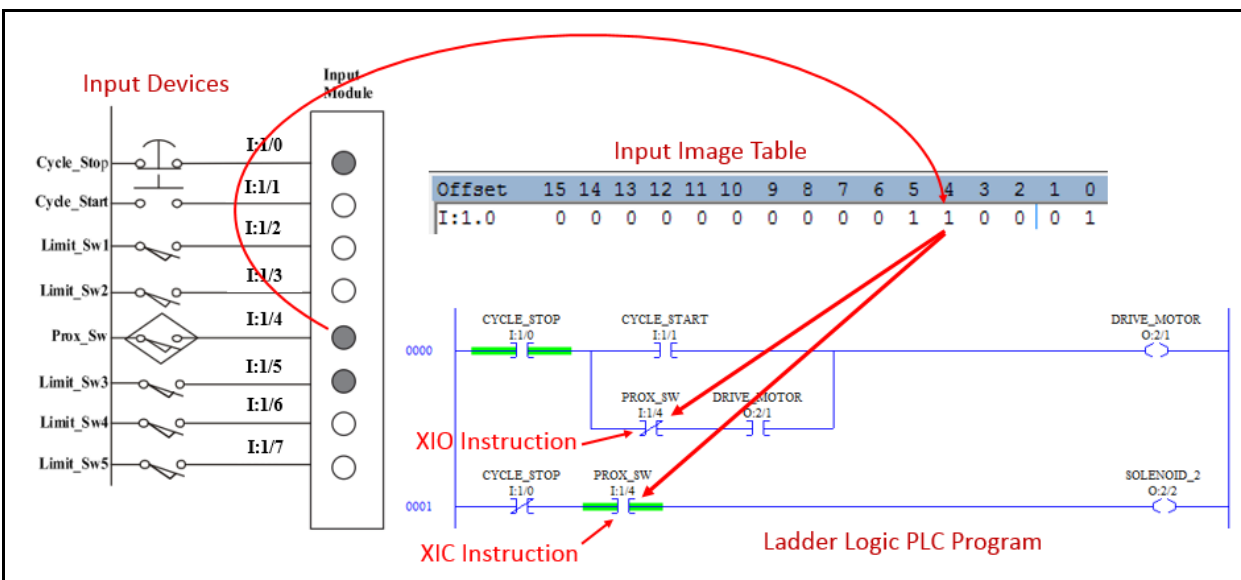

Explanation: In this graphic, the PLC input module shows the Prox_Sw (I:1/4) as being actuated, which has turned on the input status light. This will write a “1” in the corresponding address in the input image table. The processor scans the ladder and references back to the input image table. When it scans the XIO of I:1/4 it sees the “1” in the input image table and does not highlight the instruction (XIO instructions highlight when what they are addressed for is a “0”). When it scans the XIC of I:1/4 it sees the “1” in the input image table it highlights the instruction (XIC instructions highlight when what they are addressed for is a “1”). Once again, highlight means logic power flow, which in the physical world would be the same thing as continuity.

DOL DISCLAIMER:

This product was funded by a grant awarded by the U.S. Department of Labor’s Employment and Training Administration. The product was created by the grantee and does not necessarily reflect the official position of the U.S. Department of Labor. The Department of Labor makes no guarantees, warranties, or assurances of any kind, express or implied, with respect to such information, including any information on linked sites and including, but not limited to, accuracy of the information or its completeness, timeliness, usefulness, adequacy, continued availability, or ownership.



This work is licensed under a [Creative Commons Attribution 4.0 International License](https://creativecommons.org/licenses/by/4.0/).