

# BELT TENSIONING INSTRUCTIONS

## V-Belts

V-belt tensioning adjustment can be made using a tensionmeter or other type spring scale, using the following procedure. After seating the belts in the groove and adjusting center distance so as to take up slack in the belts, further increase the tension until only a slight bow on the slack side is apparent while the drive is operating under load. Stop the drive, and using the meter, measure the force necessary to depress one of the center belts  $1/64$ -inch for every inch of belt span (see sketch below). For example, a deflection for a 50-inch belt span is  $50/64$ ths, or  $25/32$ -inch. The amount of force required to deflect the belt should compare with the deflection forces noted in the chart below. Also notice for V-belts that deflection forces vary from the initial "run-in" values which are greater (reflecting higher run-in tensioning) to the "normal" values for after the run-in period.

## Synchronous Belts

High torque, Standard and Metric synchronous belts should be installed to fit pulleys snugly, neither too tight nor too loose. The belt's positive grip eliminates the need for high initial tension. When a belt is installed with a snug but not overly tight fit, longer belt life, less bearing wear and more quiet operation will result. Overtight belts can cause early failure and should be avoided. With high torque a loose belt may "jump teeth" upon startup. If such occurs, the tension should be increased gradually until satisfactory operation is achieved.

To properly tension a synchronous belt, place belt on pulleys and adjust takeup until the belt teeth mesh securely with the pulley grooves. Measure belt span "T". Then tighten belt so that it deflects  $1/64$ -inch for every inch of belt span when a force as specified in the table below is applied to the top of the belt. For belts wider than two inches, a metal or wooden strip  $3/4$  to 1-inch wide should be placed across the belt between it and the tester to prevent distortion.

The following range of deflection forces are normally adequate for drive installation. Actual installation tension required depends on peak loads, system rigidity, number of teeth in mesh, etc.

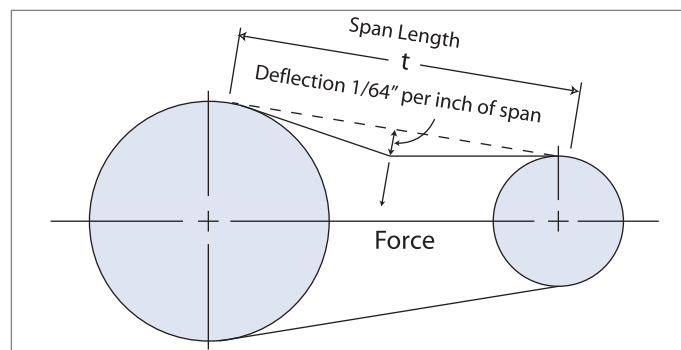

MEASURE THE SPAN LENGTH "T" AS SHOWN IN THE SKETCH ABOVE.

# BELT TENSIONING

Standard V-Belt Tensioning Deflection Force

Belt Cross-Section	Smaller Pulley Diameter Range (in.)	Deflection Force	
		Run-in (lbs.)	Normal (lbs.)
<b>A</b>	3.0-3.6	3-3/8	2-1/4
	3.8-4.8	4-1/4	2-7/8
	5.0-7.0	5-1/8	3-3/8
<b>AX</b>	3.0-3.6	4-1/8	2-3/4
	3.8-4.8	5	3-1/4
	5.0-7.0	6	4
<b>B</b>	3.4-4.2	4	2-5/8
	4.4-5.2	6	4
	5.4-9.4	7-1/8	5-1/4
<b>BX</b>	3.4-4.2	5-1/4	3-1/2
	4.4-5.2	7-1/8	4-3/4
	5.4-9.4	9	6
<b>C</b>	7.0-9.0	11-1/4	7-1/2
	9.5-16.0	15-3/4	10-1/2
<b>CX</b>	7.0-9.0	13-1/2	9
	9.5-16.0	17-1/2	11-3/4
<b>D</b>	12.0-16.0	24-1/2	16-1/2
	18.0-22.0	33	22
<b>E</b>	21.6-27.0	48	32
<b>3V</b>	3.40-4.20	6	4
	4.20-10.6	7	5
<b>3VX</b>	2.20-3.65	7	5
	4.12-10.6	8	6
<b>5V</b>	7.10-10.9	16	8-12
	11.8-16.0	20	10-15
<b>5VX</b>	4.40-10.9	18	10-14
	11.8-16.0	22	12-18
<b>8V</b>	12.5-17.0	36	18-27
	18.0-22.4	40	20-30

Synchronous Belt Tensioning Deflection Force

Belt Pitch	Belt Width	Deflection Force
<b>Synchron. 8MM (14mm)</b>	20mm	2 to 4 lbs
	30mm	3 to 6 lbs
	50mm	7 to 11 lbs
	85mm	11 to 19 lbs
<b>Synchron. 14MM (14mm)</b>	40mm	5 to 11 lbs
	55mm	8 to 17 lbs
	85mm	14 to 27 lbs
	115mm	20 to 40 lbs
	170mm	30 to 60 lbs
<b>MXL (.080-in.)</b>	1/8-inch	1 oz
	3/16-inch	1 - 1-1/2 oz
	1/4-inch	2 oz
<b>XL (1/5-in.)</b>	5/16-inch	2 - 2-1/2 oz
	1/4-inch	2-1/2 oz
	5/16-inch	3 oz
<b>L (3/8-in.)</b>	3/8-inch	3-1/2 oz
	1/2-inch	7 oz
	3/4-inch	11 oz
<b>H (1/2-in.)</b>	1-inch	1 lb
	3/4-inch	2 lbs
	1-1/2-inch	2-1/2 lbs
	2-inch	4 lbs
<b>XH (7/8-in.)</b>	3-inch	5-1/2 lbs
	2-inch	8-1/2 lbs
	4-inch	11-1/2 lbs
<b>XXH (1-1/4-in.)</b>	5-inch	16-1/2 lbs
	2-inch	7-1/2 lbs
	3-inch	11-1/2 lbs
	4-inch	20 lbs
<b>XXH (1-1/4-in.)</b>	5-inch	26 lbs
	2-inch	9 lbs
	3-inch	14 lbs

V-Ribbed Belt Tensioning Deflection Force

Belt Cross Section	Small Sheave Diameter range	Force "F" Lbs. Per Rib
<b>J</b>	1.32-1.67	0.4
<b>J</b>	1.77-2.20	0.5
<b>J</b>	2.36-2.95	0.6
<b>L</b>	2.95-3.74	1.7
<b>L</b>	3.94-4.92	2.1
<b>L</b>	5.20-6.69	2.5
<b>M</b>	7.09-8.82	6.4
<b>M</b>	9.29-11.81	7.7
<b>M</b>	12.40-15.75	8.8

*“This workforce product was funded by a grant awarded by the U.S. Department of Labor’s Employment and Training Administration. The product was created by the grantee and does not necessarily reflect the official position of the U.S. Department of Labor. The U.S. Department of Labor makes no guarantees, warranties, or assurances of any kind, express or implied, with respect to such information, including any information on linked sites and including, but not limited to, accuracy of the information or its completeness, timeliness, usefulness, adequacy, continued availability, or ownership.”*



Project Product was created by North Central Missouri College Grant Staff licensed under a [Creative Commons Attribution 4.0 International License](https://creativecommons.org/licenses/by/4.0/).