

## Lab Exercise 7



## Messages

using ControlLogix Ethernet Modules

# Student Materials for Lab Exercise 7: Messages

## Lesson Objective

By the end of this session, students should be able to:

1. Explain basic configuration of a MSG Instruction
2. Understand ControlLogix set-up for Source and Destination Chassis.
3. Program a MSG Instruction.

	<u>Page</u>
Introduction ....	3
Message Set-up.....	4
Source Chassis Set-up.....	5
Destination Chassis Set-up.....	18
Create New MSG Instruction.....	22
Review Questions .....	25

## Project Files Required for Lab Exercise

PLC220 Lab Exercise\_7\_Messages\_M3\_Destination\_Chassis.L5K

PLC220 Lab Exercise\_7\_Messages\_M3\_Source\_Chassis.L5K

## Introduction:

Allen Bradley ControlLogix PLCs can send and receive data from other processors and devices ( VFDs, DeviceNet components ) over communication networks such as Ethernet, ControlNet, DH+, DeviceNet and others.

This lesson will cover the basic set-up of a ControlLogix Message instruction.

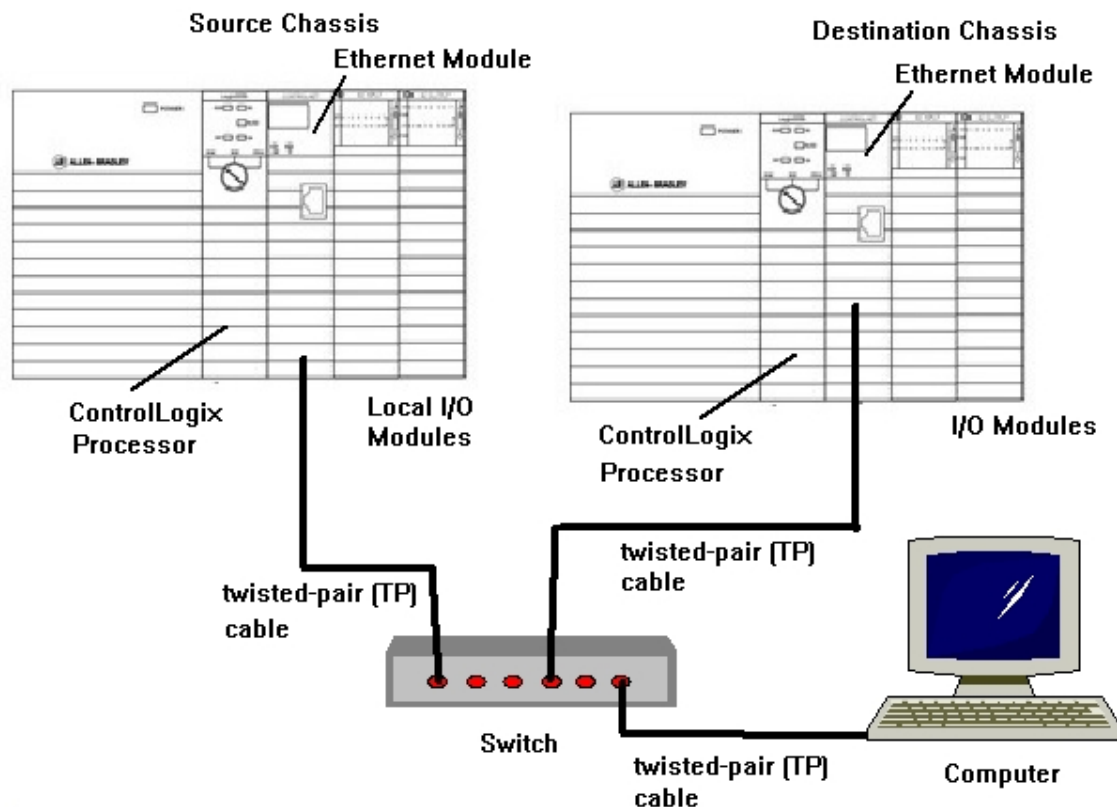

Figure 1-A  
Basic Messaging Configuration

**Source Chassis** – Chassis with ControlLogix processor, Communication Modules, Power Supply and I/O Modules (Local I/O) and the Ladder project that contains the Message Instruction

**Destination Chassis** – Chassis with ControlLogix processor, Communication Module, Power Supply and I/O Modules. The processor in the Destination Chassis will have tags that receive and/or send data to tags in the processor in the Source Chassis

**Switch** – Ethernet connection point for Computer, Local Ethernet Module and Remote Ethernet Module.

Computer – Studio 5000 software, RSLinx software, Ethernet Port, Windows 7 OS

Cabling - twisted-pair

Note: Computer and the 2 Ethernet modules must have the same Network ID  
Computer and the 2 Ethernet modules must have different Device (Host) IDs

2 Demo units - 1756-L71 processors version 24  
1756-EN2TR or 1756-ENBT Ethernet communication modules  
Discrete I/O Modules

Note: Hardware set-up for Messages is similar to Module 2 configuration for Remote chassis except that both ControlLogix chassis have processors installed.

There are numerous variations to setting-up a Message Instruction.

Message Write – Processor in Source Chassis sending values to tags in Destination Chassis processor.

Message Read – Processor in Source Chassis receiving values from tags in Destination Chassis processor.

Messages can be configured between multiple types of Allen Bradley processors.  
Some of the combinations include:

- ControlLogix to ControlLogix
- ControlLogix to CompactLogix
- ControlLogix to SLC 500
- ControlLogix to PLC 5
- SLC 500 to SLC 500
- PLC 5 to PLC 5
- PLC 5 to SLC 500
- CompactLogix to SLC 500
- 

Note: ControlLogix chassis that contain multiple processors can send / receive Messages across the ControlBus Backplane.

### **Message Set-up**

1. Determine the IP Address and Subnet Mask information for the computer

IP Address: \_\_\_\_\_

Subnet Mask: \_\_\_\_\_

2. With RSLinx - verify that there is a connection to each of the Ethernet Modules

Note: Both Ethernet modules must have the same Network ID as the computer  
Both Ethernet modules must have the same Network (Subnet) Mask as the computer

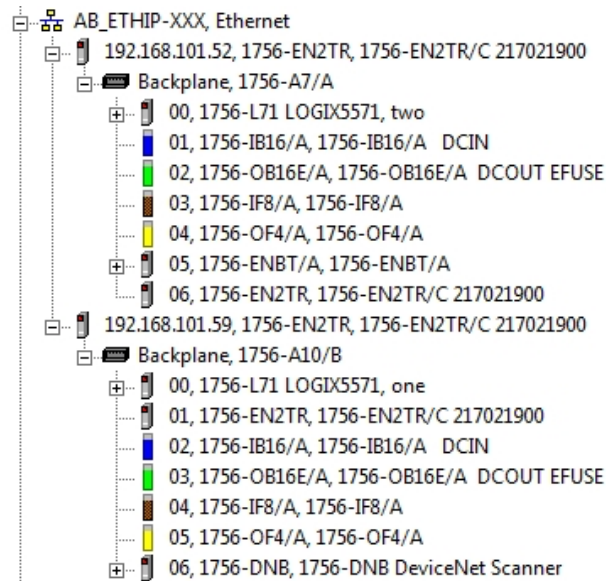

Figure 2-A - RSLinx RSWho Screen  
Ethernet Connection

In this example the chassis that contain the 1756-EN2TR module with the IP address of 192.168.101.59 will be the source chassis.  
1756-L71 processor located in slot 0.

In this example the chassis that contain the 1756-EN2TR module with the IP address of 192.168.101.52 is the destination chassis.  
1756-L71 processor located in slot 0..

### Source Chassis

3. Open the Project File - Module\_3\_Source\_Chassis.L5K, Import in to Studio 5000.

4. Navigate to and expand the I/O Configuration folder.

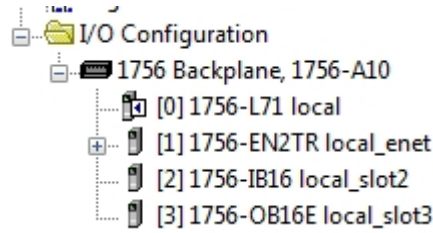

Figure 3-A  
I/O Configuration Folder

- Open the Properties window for the 1756-EN2TR Ethernet module.  
This is the Ethernet Module in the Source Chassis.

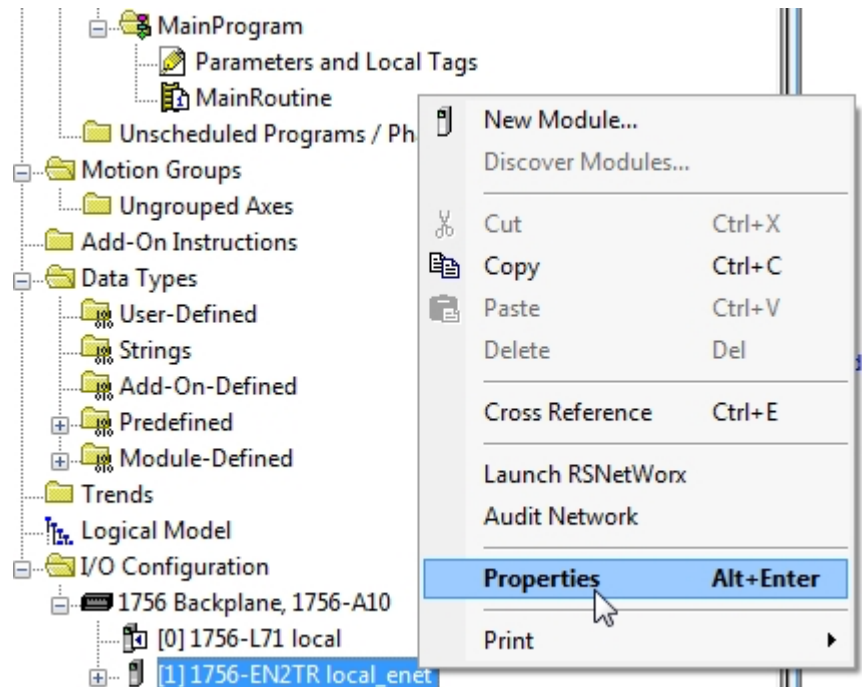

Figure 4-A  
Navigate to 1756-EN2TR Properties

- View General tab Information

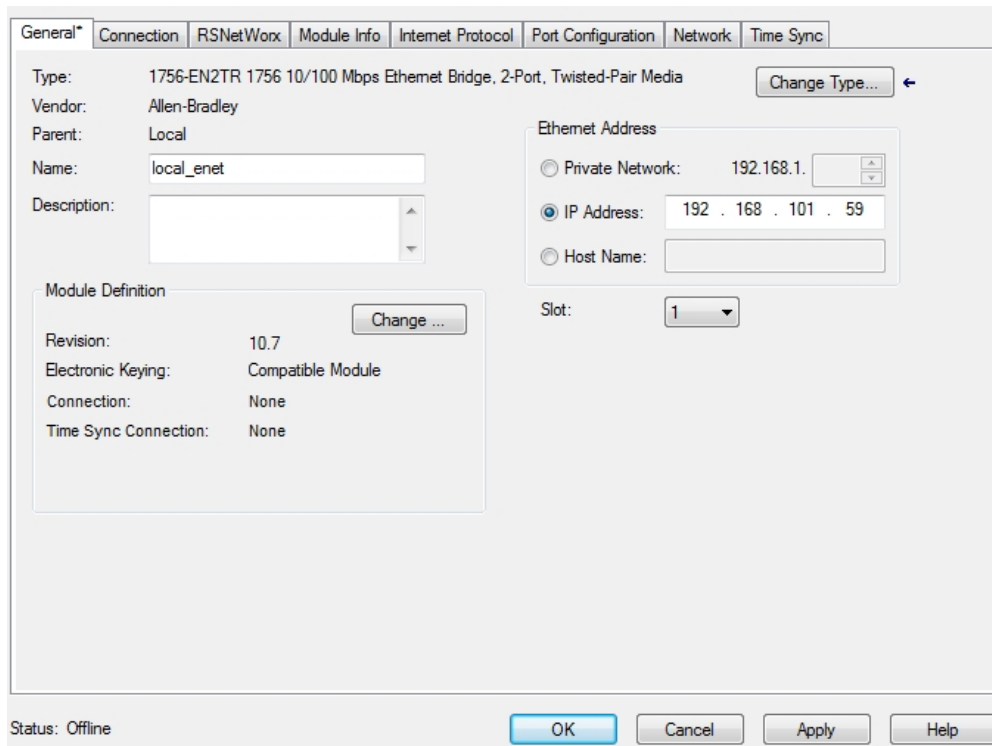

Figure 5-A  
1756-EN2TR Properties – General Tab

Verify the following configuration settings:

Type: Match actual module's Part Number

Parent: Local – Module in the same chassis as processor

Name: Module name – user defined

IP Address: Must match to module's actual IP address

If address does not match change either module's IP address to match the IP Address setting on General tab or change the IP Address setting on the General tab to match the actual IP address of the module.

Slot: Must match the actual slot location of module

Electronic Keying: Based in module's revision

7. Navigate back to I/O Configuration folder on the Controller Organizer window

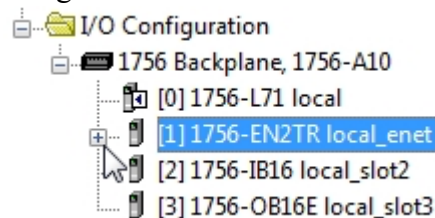

Figure 6-A

8. Click the plus (+) sign to the left of the local Ethernet module,

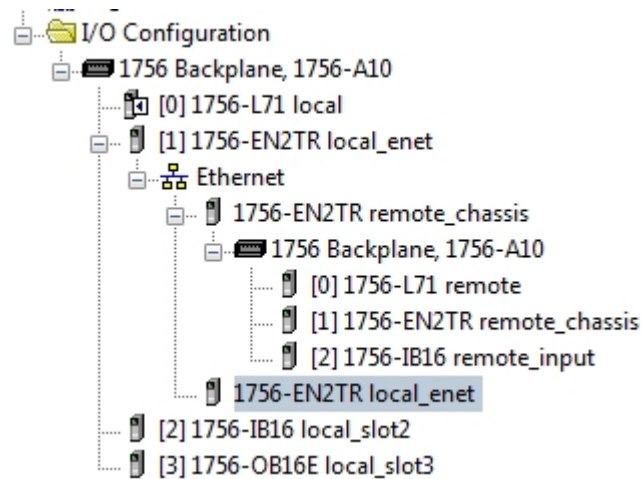

Figure 7-A

The information listed under [1] 1756-EN2TR local\_enet is the configuration information for the Destination chassis.

Destination Chassis (Backplane) is a 10 slot chassis – 1756-A10

In slot 0 of the destination chassis is a 1756-L71 processor –  
[0] 1756-L71 remote

In slot 1 of the Destination chassis is the communication module –  
[1] 1756-EN2TR remote\_chassis

In slot 2 of the Destination Chassis is a 16 point input module –  
[2] 1756-IB16 remote\_input

This information must match the modules' location in the Destination chassis.

9. Right click [1] 1756-EN2TR remote\_chassis to open its Properties window



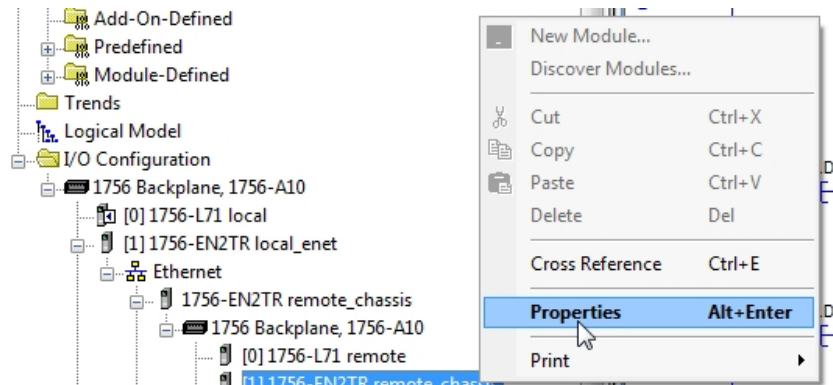

Figure 8-A

10. Navigate to General tab for [1] 1756-EN2TR remote\_chassis module.

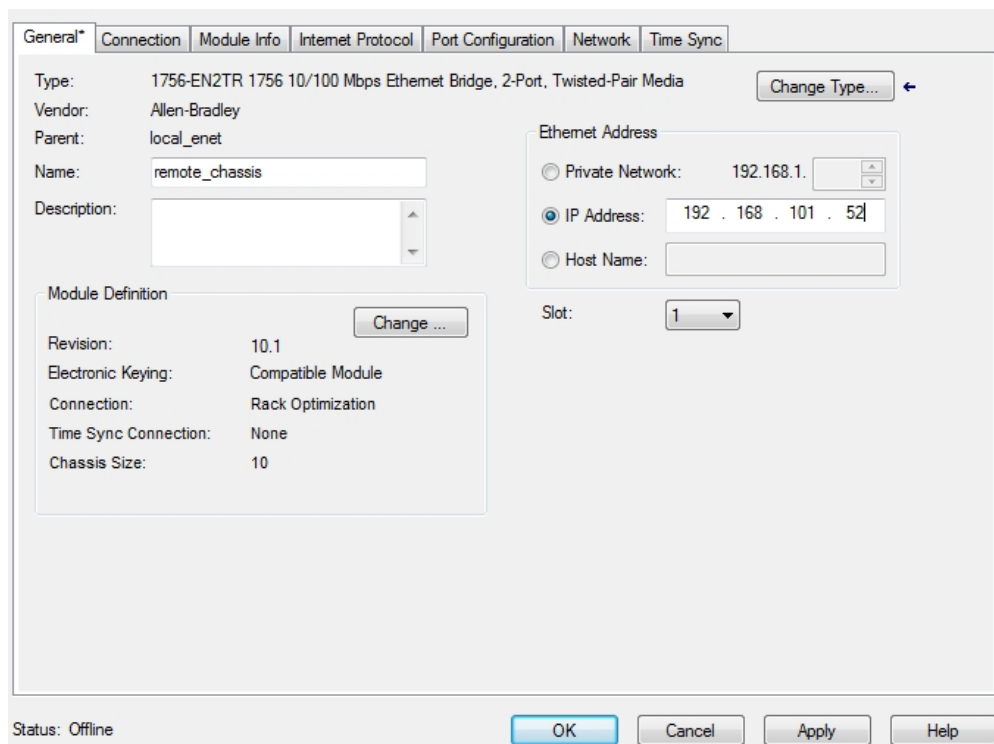

Figure 9-A

Destination Chassis Ethernet Module's Properties Window – General Tab

Verify the following configuration settings:

Type: Match actual module's Part Number

Parent: local\_enet – Name of the Ethernet Communication module in the local chassis

Name: Module name – user defined

IP Address: Must match to module's actual IP address

If address does not match change either module's IP address to match the IP Address setting on General tab or change the IP Address setting on the General tab to match the actual IP address of the module.

Slot: Must match the actual slot location of module

Electronic Keying: Based in module's revision

Chassis Size: Number of Slots in Remote Chassis – must match to actual chassis size

Use Change button to modify Chassis Size, Revision and Electronic Keying settings

11. Navigate to Ladder Logic window - MainRoutine.

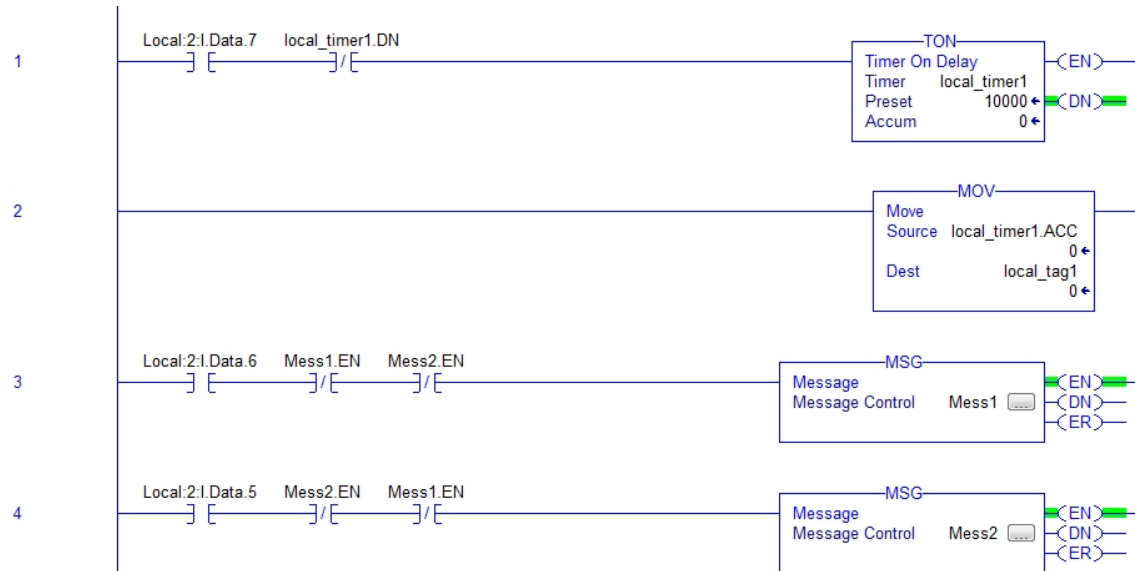

Figure 10-A – MainRoutine – Ladder Logic Window

Note: Message – MSG – Instructions at Rungs 3 and 4

MSG Instruction is listed on Input/Output tab on Language Toolbar.

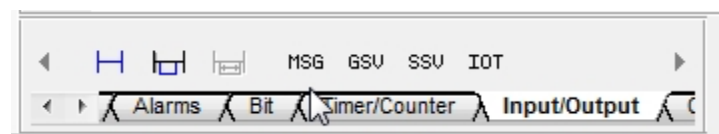

Figure 11-A  
MSG Instruction - Input / Output Tab

12. At Rung 3 – Monitor the Message Instruction Control Tag – Mess1.



Figure 12 -A  
Message Tag

Right click the tag Mess1 and choose Monitor Mess1 from the context menu.

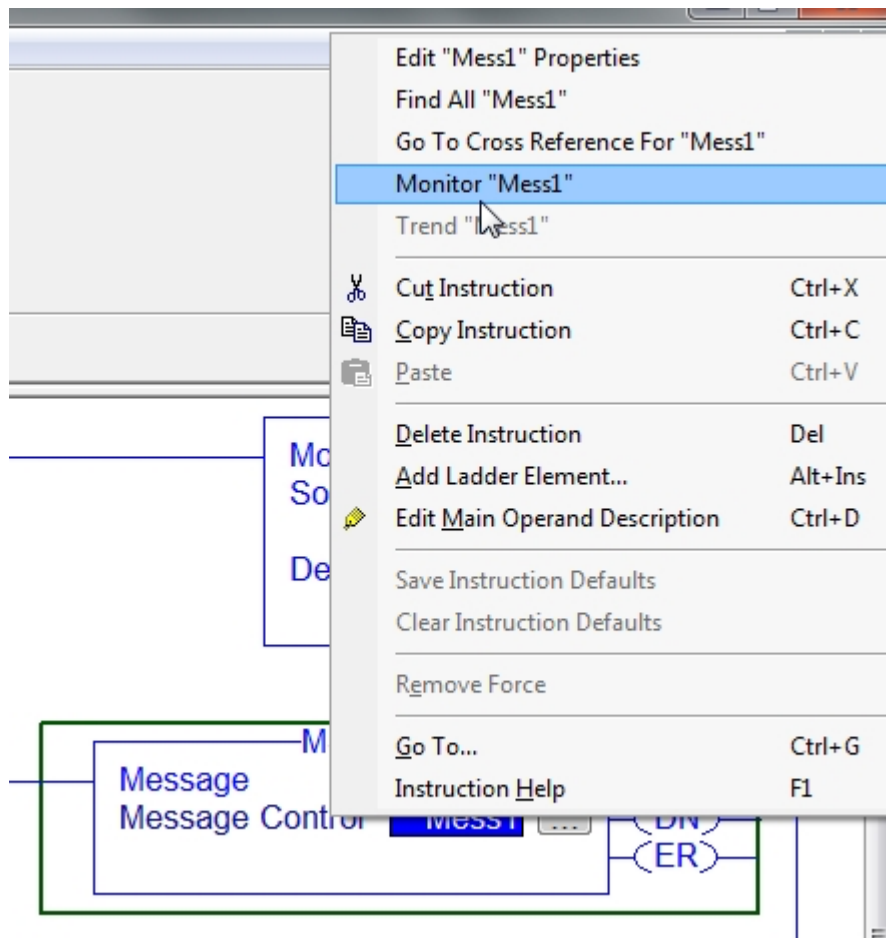

Figure 13 - A Mess1 Tag

13. From the Controller Tag window –
  - Data Type for Message tag is MESSAGE
  - Click the + sign to the left of Mess1 to view the data structure of the Message Control

tag – Mess1

Scope: local Show: All Tags

Name	Value	Force Mask	Style	Data Type
+ Local:2:C	{...}	{...}		AB:1756_DI:C:0
+ Local:2:I	{...}	{...}		AB:1756_DI:I:0
+ Local:3:C	{...}	{...}		AB:1756_DO:C:0
+ Local:3:I	{...}	{...}		AB:1756_DO_Fus...
+ Local:3:O	{...}	{...}		AB:1756_DO:O:0
+ local_array	{...}	{...}	Decimal	DINT[10]
+ local_tag1	0		Decimal	DINT
+ local_timer1	{...}	{...}		TIMER
+ Mess1	{...}	{...}		MESSAGE
+ Mess2	{...}	{...}		MESSAGE
+ remote_chassis:2:C	{...}	{...}		AB:1756_DI:C:0
+ remote_chassis:2:I	{...}	{...}		AB:1756_ENET_...
+ remote_chassis:I	{...}	{...}		AB:1756_ENET_...
+ remote_chassis:O	{...}	{...}		AB:1756_ENET_...

Figure 14-A  
Mess1 Data Type

Name	Value	Force Mask	Style	Data Type
- Mess1	{...}	{...}		MESSAGE
+ Mess1.Flags	16#0280		Hex	INT
- Mess1.EW	0		Decimal	BOOL
- Mess1.ER	0		Decimal	BOOL
- Mess1.DN	0		Decimal	BOOL
- Mess1.ST	0		Decimal	BOOL
- Mess1.EN	1		Decimal	BOOL
- Mess1.TO	0		Decimal	BOOL
- Mess1.EN_CC	1		Decimal	BOOL
+ Mess1.ERR	16#0000		Hex	INT
+ Mess1.EXERR	16#0000_0000		Hex	DINT
+ Mess1.ERR_SRC	0		Decimal	SINT
+ Mess1.DN_LEN	0		Decimal	INT
+ Mess1.REQ_LEN	1		Decimal	INT
+ Mess1.DestinationLink	0		Decimal	INT
+ Mess1.DestinationNode	8#000_000		Octal	INT
+ Mess1.SourceLink	0		Decimal	INT
+ Mess1.Class	16#0000		Hex	INT
+ Mess1.Attribute	16#0000		Hex	INT
+ Mess1.Instance	0		Decimal	DINT
+ Mess1.LocalIndex	0		Decimal	DINT
+ Mess1.Channel	'\$00'		ASCII	SINT
+ Mess1.Rack	8#000		Octal	SINT
+ Mess1.Group	0		Decimal	SINT
+ Mess1.Slot	0		Decimal	SINT

Figure 15-A  
Message Tag Structure

14. Return to the Ladder Logic window

Right click on the MSG instruction at Rung 3.  
Select Instruction Help from the context menu.

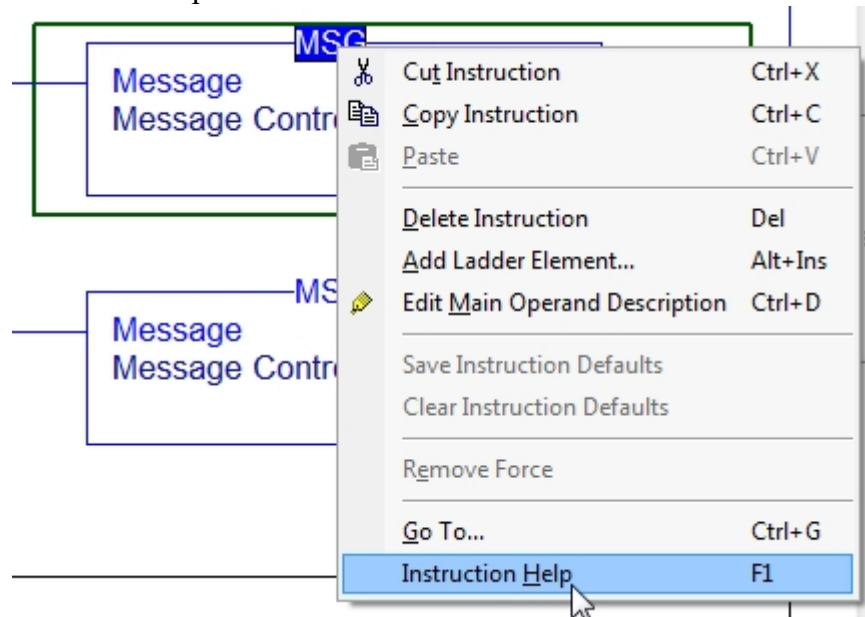

Figure 16-A  
Instruction Help

The Help window for the MSG Instruction opens.

Print

### Message (MSG)

The MSG [instruction](#) asynchronously reads or writes a block of data to another module on a network.

**Available Languages**

**Ladder Diagram**



**Function Block**

This instruction is not available in function block.

**Structured Text**

MSG(MessageControl);

**Operands**

**Ladder Diagram**

Operand Type	Format	Description
Message	Message <a href="#">tag</a>	<a href="#">message structure</a>

**Structured Text**

Operand Type	Format	Description
Message	Message <a href="#">tag</a>	<a href="#">message structure</a>

**MESSAGE Structure**

If you check the status bits more than once, the controller changes the DN, ER, EW, and ST bits asynchronous to the scan of your logic. Use a copy of the bits if you check them in more than one place in your logic. Otherwise, the bits may change during the scan and your logic won't work as you expect it.

One way to make a copy is to use the FLAGS word. Copy the FLAGS word to another tag and check the bits in the copy.

---

**Important:** Do not change the following bits of a MSG instruction:

- DN

Figure 17-A  
MSG Instruction Help Window

15. Return to the Ladder Logix window

Click the ellipse button to the right of Mess1 on the MSG instruction to view the Configuration window for the MSG instruction – Configuration tab



Figure 18-A  
Ellipse Button

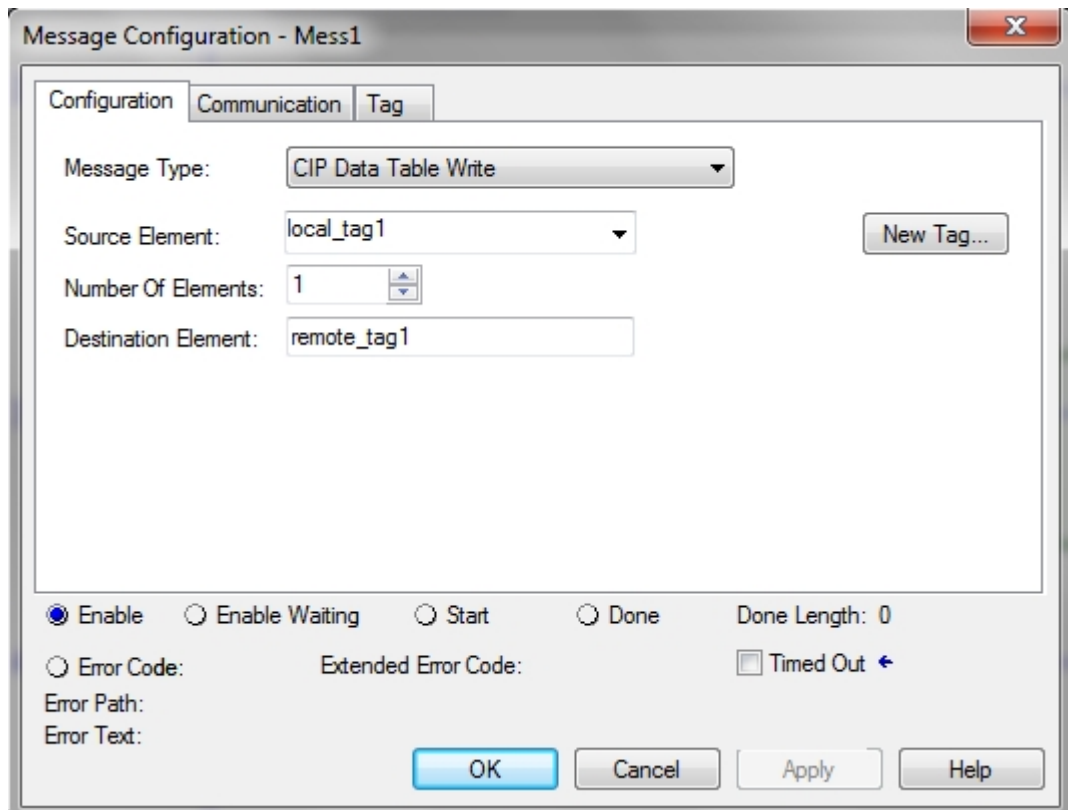

Figure 19-A  
MSG Configuration Tab

Message Type: Type of Message Instruction

In Figure 19-A CIP Data Table Write will send the value of the Source Element tag to the Destination Element Tag

Source Element: for a Write Message type, tag is located in the processor in Source Chassis

for a Read Message type, tag is located in the processor in Destination Chassis

Number of Elements: Number of elements to be transferred

Destination Element: for a Write Message type, tag is located in the processor in Destination Chassis

for a Read Message type, tag is located in the processor in Source Chassis

Note: for ControlLogix / CompactLogix processors tag must be Controller Scoped Tags

Click the Message Type pull-down menu to see available Message Types.

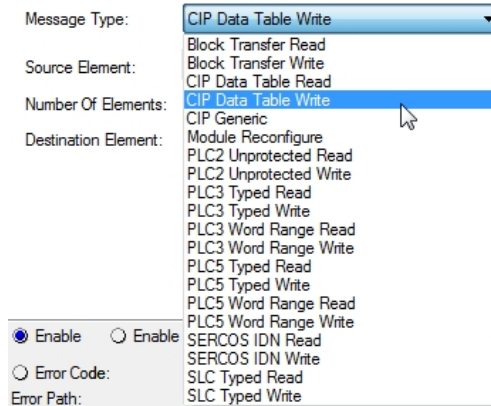

Figure 20-A - Available Message Types

16. Click the Communication tab to view Path information

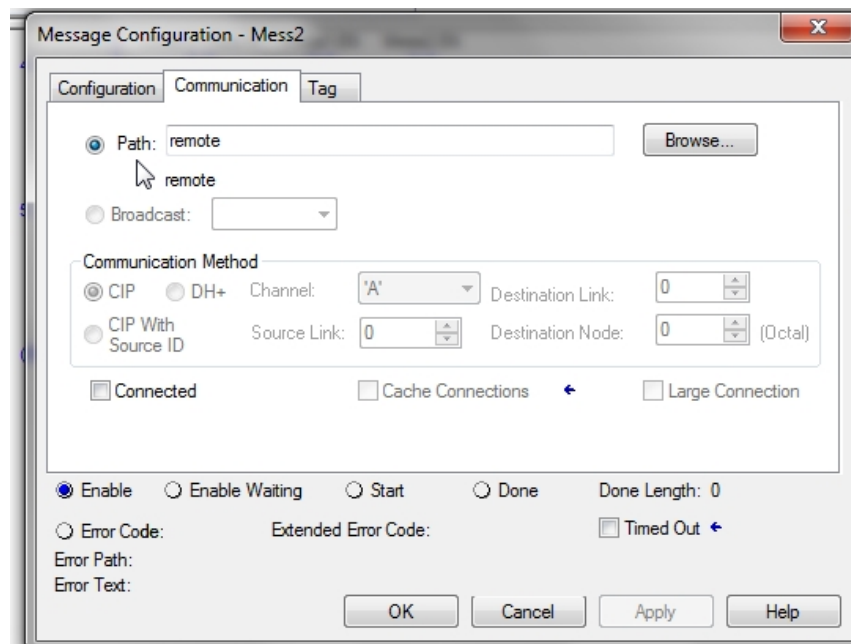

Figure 21-A

#### Communication Path

Path: Shows the name of the Destination processor as listed in the I/O Configuration folder of Source chassis hardware

Note: The name of the Destination processor as listed in the I/O Configuration folder of the Source chassis does not have to match actual processor name..

An alternate way of showing the Path setting is shown in Figure 22 – A.



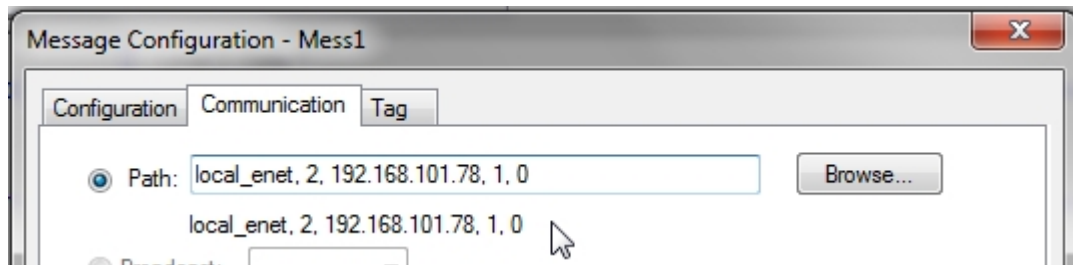

Figure 22-A  
Alternate Communication Path Setting

- local\_enet – name of Ethernet Module in Source Chassis
- 2 – RJ-45 port on Ethernet Module in Source Chassis
- 192.168.101.78 – IP address of Ethernet Module in Destination Chassis
- 1 – backplane of the Destination Chassis
- 0 - Slot location of processor in the Destination Chassis

To reconfigure the Path click the Browse button

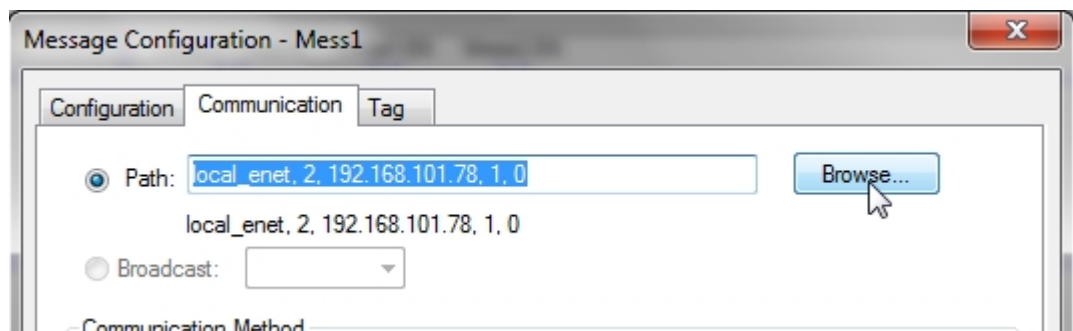

Figure 23-A  
Browse Button

The Message Path Browser window opens.

See Figure 24-A

Select the processor located in the Destination Chassis from the I/O Configuration folder.

In the I/O Configuration Folder shown in Figure 24 – A, the processor in the Destination folder is named Remote.

Note: The name of the Destination processor as listed in the I/O Configuration folder of the Source chassis does not have to match actual processor name..

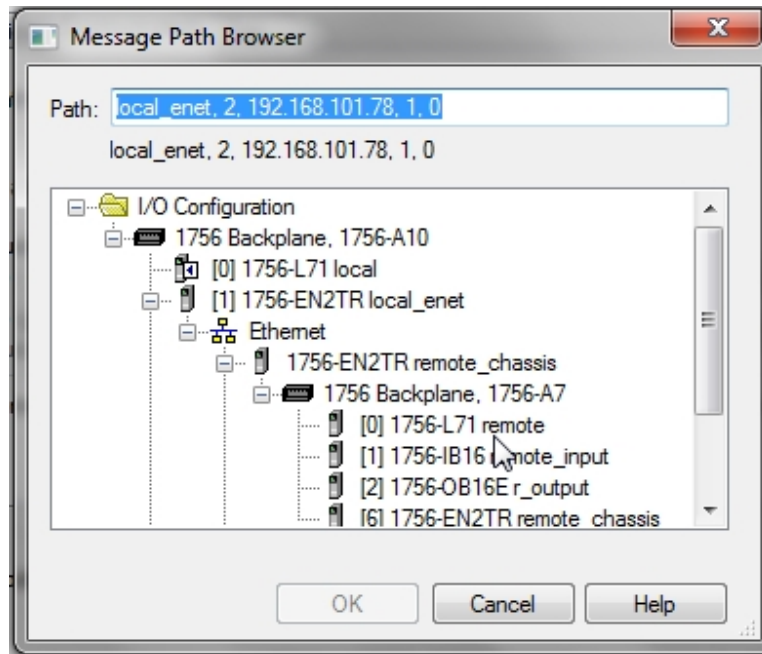

Figure 24-A  
Message Path Browser Window

Click the OK button on the Message Path Browser window to return to the Message Configuration window – Communication tab.

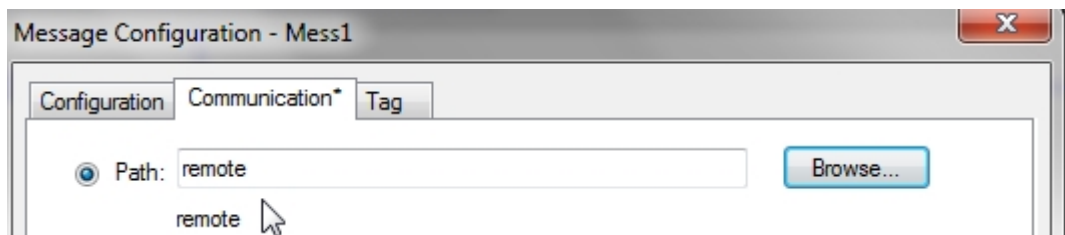

Figure 25-A  
Message Path Browser Window

Path is now set to processor located in Destination Chassis.

Note: The name of the Destination processor as listed in the I/O Configuration folder of the Source chassis does not have to match actual processor name.

Click the Configuration tab to return to the Configuration window

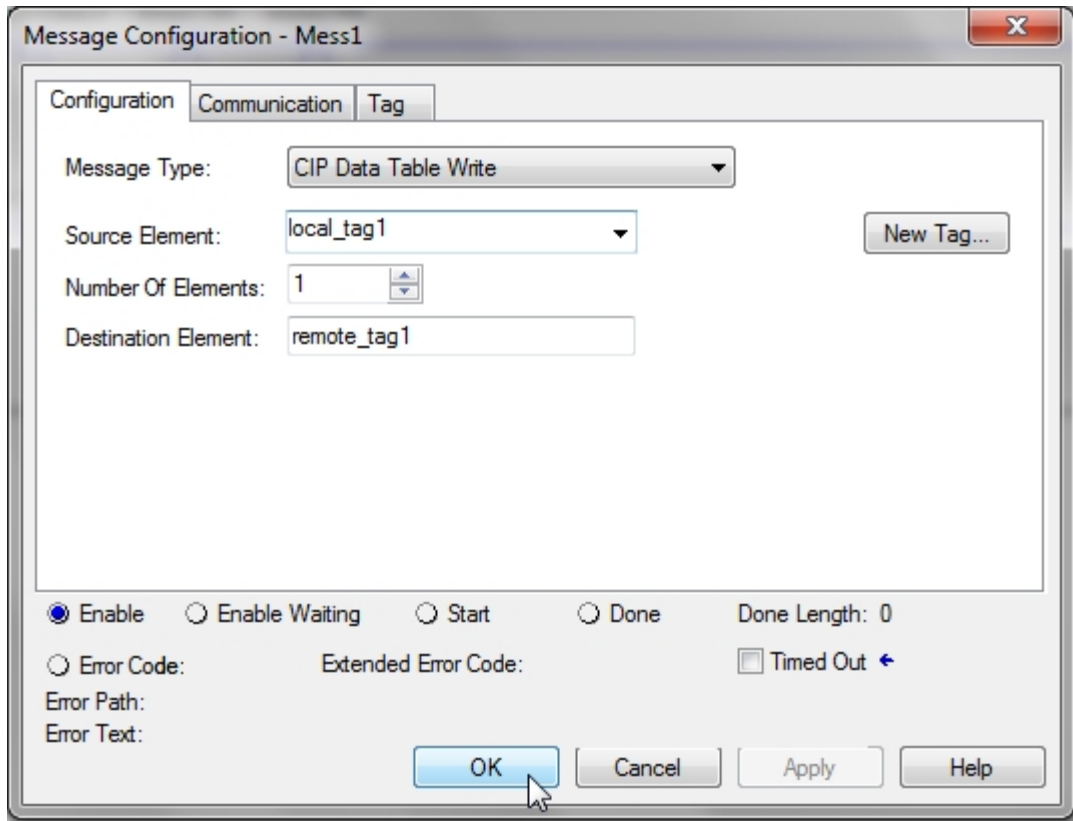

Figure 26-A  
Message Configuration Tab

Note: Source Element and Destination Elements tags.

Source Element: \_\_\_\_\_

Destination Element: \_\_\_\_\_

Note: Source and Destination must be Controller Scoped tags and of similar Data Types.

Click the OK button to close the Message Configuration Window

17. Navigate to the Controller Tags window.

+ Local:3:I		{...}	{...}		AB:1756_DO_Fus...
+ Local:3:O		{...}	{...}		AB:1756_DO:0:0
+ local_array		{...}	{...}	Decimal	DINT[10]
+ local_tag1	▼		0	Decimal	DINT
+ local_timer1		{...}	{...}		TIMER
+ Mess1		{...}	{...}		MESSAGE

Figure 27-A  
Controller Scoped Tags – Source Processor

Data Type of local\_tag1: \_\_\_\_\_  
18. Close the Controller tag window

19. View Ladder Logic window – Rung 4

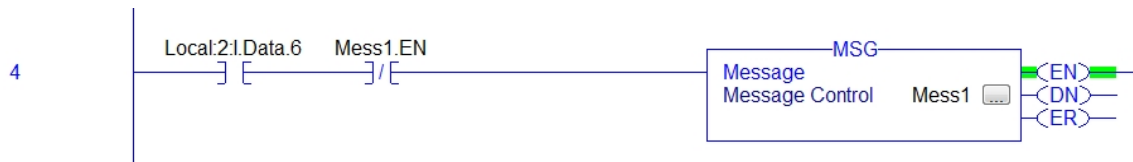

Figure 28-A  
Ladder Logic – Source Processor

A MSG instruction operates on a False to True transition of rung conditions.

The rung condition(s) must toggle False then True for the MSG instruction to function again

A condition the toggles from False to True will have the MSG operate one time no matter how long the condition remains True.

The ENABLE bit (EN) of the Message tag will provide a continual toggling of a condition of a MSG rung.

Note: on Rung 4 in Figure 28-A - MSG tag is Mess1  
ENALBE bit for Mess1 tag is Mess1.EN

## Destination Chassis

19. Open the Project File - Module\_3\_Destination\_Chassis.L5K, Import in to Studio 5000

20. View I/O Configuration Folder

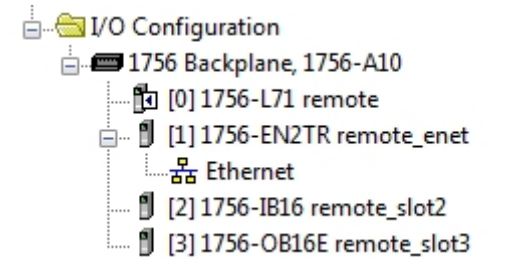

Figure 29-A  
I/O Configuration – Destination Chassis

- 1756 Backplane, 1756-A10 – Chassis size for Destination Chassis  
 [0] 1756-L71 remote – Processor in Destination Chassis  
 [1] 1756-EN2TR remote\_enet – Ethernet module in Destination Chassis  
 [2] 1756-IB16 remote\_slot2 – input module in Destination Chassis  
 [3] 1756-OB16E remote\_slot3 – output module in Destination Chassis  
 21. Navigate to Property window -> General tab of 1756-EN2TR module.

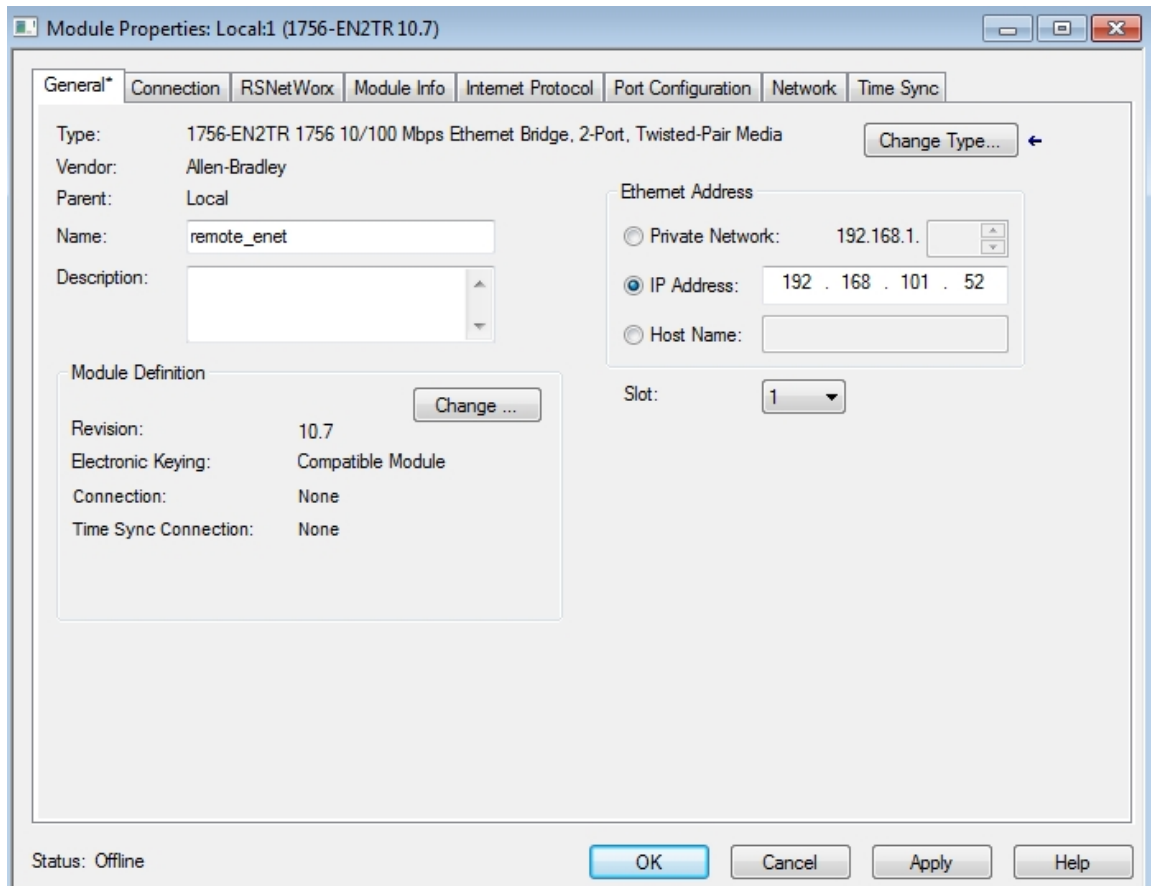

Figure 30-A  
 General Tab- 1756-EN2TR Module – Destination Chassis

IP Address: must match actual IP address of Ethernet Module in Destination Chassis  
 Slot: must match actual Slot location of Ethernet Module in Destination Chassis

22. Navigate to the Controller Scoped Tags

Scope: destination Show: All Tags Enter Name Filter...

Name	Value	Force Mask	Style	Data Type
destination_tag2	11111111		Decimal	DINT
Local:1:C	{...}	{...}		AB:1756_DI:C:0
Local:1:I	{...}	{...}		AB:1756_DI:I:0
Local:2:C	{...}	{...}		AB:1756_DO:C:0
Local:2:I	{...}	{...}		AB:1756_DO:Fus...
Local:2:O	{...}	{...}		AB:1756_DO:O:0
remote_array	{...}	{...}	Decimal	DINT[10]
remote_tag1	2249		Decimal	DINT
timer_acc	2243		Decimal	DINT

Figure 31-A  
Controller Scoped tags – Destination Chassis

What is the Data Type of remote\_tag1: \_\_\_\_\_

View Figure 26 – A

What is the Destination Element on Message Configuration window?

\_\_\_\_\_

View Figure 27-A

What is the Data Type of the Source Element tag on the Message Configuration window – local\_tag1? \_\_\_\_\_

Note: Source and Destination must be Controller Scoped tags and of similar Data Types.

23. Connect demo equipment as shown in Figure 1-A

24. Modify settings in Module\_3\_Source\_Chassis.ACD project file to match demo board equipment for the demo board that will be the Source Chassis, i.e. IP Addresses

Modify settings in Module\_3\_Destination\_Chassis.ACD project file to match demo board equipment for the demo board that will be the Destination Chassis, i.e. IP Address information..

25. Download Project File Module\_3\_Source\_Chassis.ACD to Source Chassis

ControlLogix demo board

• Ensure Processor is in Run Mode

Download Project File Module\_3\_Destination\_Chassis.ACD to Destination Chassis

ControlLogix demo board

Ensure Processor is in Run Mode

26. Navigate to Ladder Logic – Source Processor



Figure 32-A  
Ladder Logic - Source Chassis

Turn ON SS7 switch to start TON timer – Rung 1

Turn ON SS6 switch to enable MSG instruction – Rung 3

If the MSG instruction is operating properly the DN and EN bits on the right side of the instruction will highlight.



Figure 33-A  
MSG Instruction Operating Correctly

If the ER (Error) bit on the right side of the MSG Instruction is highlighted there are errors with either I/O Configuration settings or MSG instruction settings



Figure 34-A  
MSG Instruction Operating Incorrectly

Recheck

- Cabling is correct between computer and demo boards
- IP Addressing of Ethernet Modules vs. Properties - General Tab IP Address settings on Ethernet Modules General Tab

- Slot location of actual modules match the settings in Module's Properties - General Tab
- Source and Destination Element tags are created and available in Controller Tags
- Ensure tag's Data Types are compatible
- Path information in MSG instruction matches the I/O Configuration Folder information

27. If everything is functioning – the remote\_tag1 in the Destination Processor will be changing values when local\_timer1 and MSG instruction Mess1 are enable in the Source Processor. View MOV instruction Rung 1.

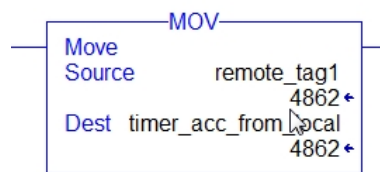

Figure 35-A  
remote\_tag1 – Destination Processor

28. View the MSG instruction with a control tag – Mess2 – in the Source Processor Rung 4



Figure 36-A  
MSG Mess2 – Source Processor

Mess2 Path: \_\_\_\_\_

Mess2 Source Element: \_\_\_\_\_

Mess 2 Number of Elements: \_\_\_\_\_

Mess 2 Destination Element: \_\_\_\_\_

From I/O Configuration in Source Project File –  
Name of Destination Processor: \_\_\_\_\_

From I/O Configuration in Destination Project File –  
Name of Destination Processor: \_\_\_\_\_

Are the Destination tags created in the Destination Processor? \_\_\_\_\_



Are the Source tags created in the Source Processor? \_\_\_\_\_

Does the MSG Mess2 instruction operate properly? \_\_\_\_\_

## Create New MSG Instruction

29. Create a tag named destination\_tag2 – DINT Data Type – in the Destination processor

Create a tag named source\_tag2 – DINT Data Type – in the Source Processor

Add a Rung of Ladder Logic similar to Figure 37 – A – in the Source Processor.



Figure 37 – A

MSG Control Tag – Mess3

Configure the MSG Configuration window as shown in Figure 38 –A.

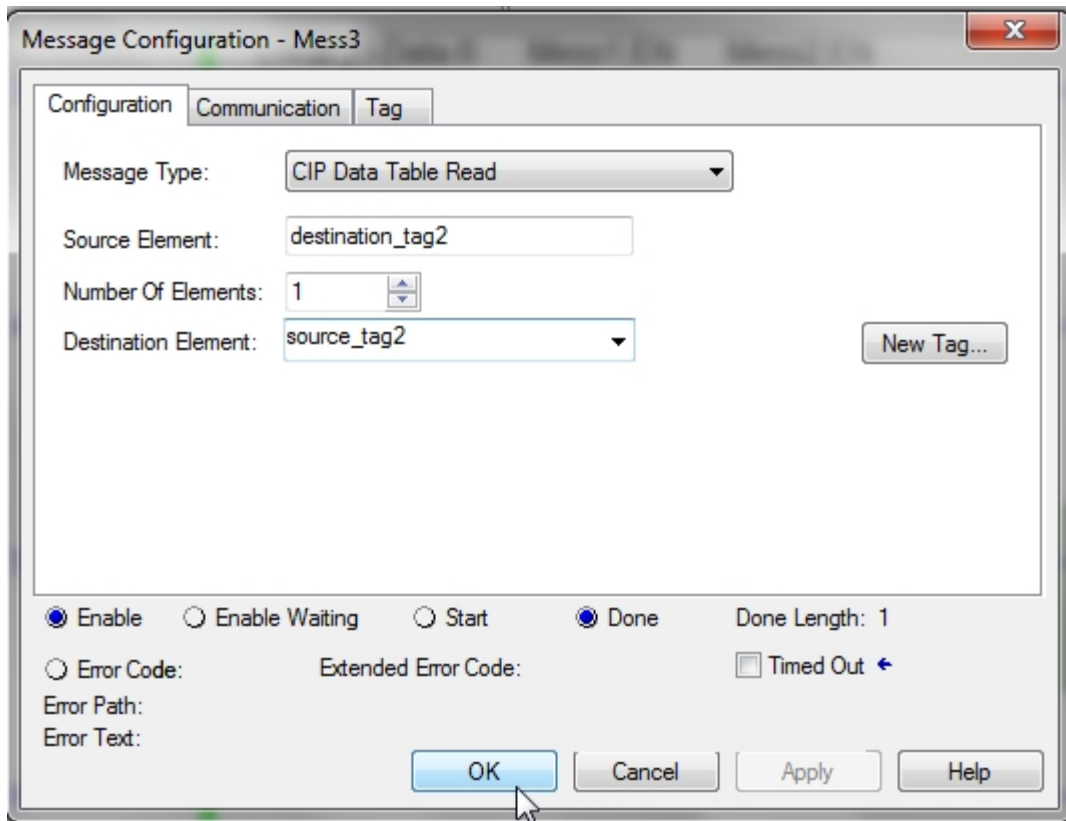

Figure 38 – A  
MSG Mess3 – Configuration Window

Note: Message Type: CIP Data Table Read

Use the same Communication Path as the MSG Mess1 Instruction Path if the Mess1 Instruction is operating correctly.

30. Download modified Project files to the specific processors.  
Ensure processors are in RUN mode

31. In the Controller tags of the Destination Processor – enter a value for destination\_tag2

Name	Value	Force Mask	Style	Data Type
destination_tag2	345		Decimal	DINT
Local:1:C	{...}	{...}		AB:1756_DI:C:0
Local:1:I	{...}	{...}		AB:1756_DI:I:0

Figure 39 – A  
destination\_tag2 – Destination Processor

32. Navigate to the Source Processor – Ladder Logic window



Figure 40 – A  
Mess3 MSG Instruction – Source Processor

Toggle SS4 switch on Source Processor demo board

Ensure Mess3 instruction operates correctly  
EN and DN bits highlights

33. Navigate to Controller Tag window – Source Processor

+ remote_chassis:1:C	{...}	{...}		AB:1756_DI:C:0
+ remote_chassis:1:I	{...}	{...}		AB:1756_ENET_...
+ remote_chassis:I	{...}	{...}		AB:1756_ENET_...
+ remote_chassis:O	{...}	{...}		AB:1756_ENET_...
+ source_tag2		345	Decimal	DINT

Figure 41 – A  
Source\_tag2 Value – Source Processor

The source-tag2 value will be the same valued entered in the destination\_tag2 in the Destination Processor – See Figure 39 - A

## Review Questions

1. T F Remote Chassis must be connected using Ethernet.
2. The communication module must be located in what slot of a chassis?
  - a) 6
  - b) Right most slot
  - c) 0
  - d) Doesn't matter
3. A communication module in a remote chassis is named – Machine\_1, I/O tags in the chassis will be named:
  - a) Remote\_Chassis:
  - b) Local:
  - c) Machine\_1:
  - d) It depends on module address
4. A tag called LINE6:4:I.Data.3 is being used. Where is the module located.
  - a) A Local Chassis , Slot 6
  - b) A Remote chassis, Slot 6
  - c) A Remote chassis, Slot 4
  - d) A Remote chassis, Slot 3

5. A tag called LINE6:4:I.Data.3 is being used. What module terminal is being referenced?
  - a) 6
  - b) 4
  - c) 3
  - d) 1
  
6. T F A remote chassis does not require a processor.
  
7. A tag called LINE6:4:I.Data.3 is being used. What type of data is being referenced?
  - a) Analog Input
  - b) Analog Output
  - c) Discrete Input
  - d) Discrete Output
  
8. The processor I/O Fault has does not reference remote I/O modules:
  - a) True
  - b) False

## Review Question Answers

- 1) F
- 2) d
- 3) c
- 4) c
- 5) c
- 6) T
- 7) c
- 8) F

### DOL DISCLAIMER:

This product was funded by a grant awarded by the U.S. Department of Labor's Employment and Training Administration. The product was created by the grantee and does not necessarily reflect the official position of the U.S. Department of Labor. The

Department of Labor makes no guarantees, warranties, or assurances of any kind, express or implied, with respect to such information, including any information on linked sites and including, but not limited to, accuracy of the information or its completeness, timeliness, usefulness, adequacy, continued availability, or ownership.



This work is licensed under a [Creative Commons Attribution 4.0 International License](https://creativecommons.org/licenses/by/4.0/).